



# Model 410

CODE \_\_\_\_\_

SN \_\_\_\_\_

VERSION \_\_\_\_\_

This Manual contains important information.  
PLEASE READ PRIOR TO USE.



## WARRANTY

All products manufactured by Mensor® Corporation are warranted to be free of defects in workmanship and materials for a period of one year from the date of shipment. No other express warranty is given, and no affirmation of Seller, by words or actions, shall constitute a warranty. SELLER DISCLAIMS ANY IMPLIED WARRANTIES OF MERCHANTABILITY OR FITNESS FOR ANY PARTICULAR PURPOSES WHATSOEVER. If any defect in workmanship or material should develop under conditions of normal use and service within the warranty period, repairs will be made at no charge to the original purchaser, upon delivery of the product(s) to the factory, shipping charges prepaid. If inspection by Mensor Corporation or its authorized representative reveals that the product was damaged by accident, alteration, misuse, abuse, faulty installation or other causes beyond the control of Mensor Corporation, this warranty does not apply. The judgment of Mensor Corporation will be final as to all matters concerning condition of the product, the cause and nature of a defect, and the necessity or manner of repair. Service, repairs or disassembly of the product in any manner, performed without specific factory permission, voids this warranty.

MENSOR CORPORATION MAKES NO WARRANTY OF ANY KIND WITH REGARD TO THIS MANUAL, INCLUDING, BUT NOT LIMITED TO, THE IMPLIED WARRANTIES OF MERCHANTABILITY AND FITNESS FOR A PARTICULAR PURPOSE. Mensor Corporation shall not be liable for errors contained herein or for incidental or consequential damages in connection with the furnishing, performance, or use of this material.



### WARNING!

PRESSURIZED VESSELS AND ASSOCIATED EQUIPMENT ARE POTENTIALLY DANGEROUS. THE APPARATUS DESCRIBED IN THIS MANUAL SHOULD BE OPERATED ONLY BY PERSONNEL TRAINED IN PROCEDURES THAT WILL ASSURE SAFETY TO THEMSELVES, TO OTHERS, AND TO THE EQUIPMENT. THE USERS, THROUGH THEIR OWN ANALYSIS AND TESTING, ARE RESPONSIBLE FOR ASSURING THAT ALL PERFORMANCE, SAFETY AND WARNING REQUIREMENTS ARE MET, AND FOR THE TRAINING OF THE USER PERSONNEL IN THE OPERATION OF HIGH PRESSURE SYSTEMS.

DO NOT EXCEED SAFE MAXIMUM GENERATED PRESSURES AS DEFINED IN THIS MANUAL.

WHEN ANY MAINTENANCE IS PERFORMED, TURN OFF POWER AND REMOVE POWER CORD.

ALWAYS USE REPLACEMENT PARTS SPECIFIED BY MENSOR CORPORATION.

# TABLE OF CONTENTS

<b>WARRANTY</b> . . . . .	ii
<b>INTRODUCTION</b> . . . . .	1
<b>SAFETY FIRST</b> . . . . .	3
<b>INSTALLATION</b> . . . . .	3
<b>MODES OF OPERATION</b> . . . . .	4
Test Mode . . . . .	5
Gauge/Absolute Emulation Mode . . . . .	5
Standby Mode . . . . .	5
Measure Mode . . . . .	5
Control Mode . . . . .	5
Vent Mode . . . . .	5
<b>MAINTENANCE</b> . . . . .	6
<b>SAFETY FEATURES AND ERROR CONDITIONS</b>	
Clear Error in Local Operation . . . . .	6
Clear Error in Remote Operation . . . . .	6
Error Code E60 - High Pressure Control Unit Off . . . . .	6
Error Code E61 - High Pressure Controller Unit Error . . . . .	6
<b>REMOTE OPERATION</b> . . . . .	7
<b>SPECIFICATIONS</b>	
General Specifications . . . . .	7
Measurement Specifications . . . . .	9
Control Specifications . . . . .	9
<b>OPTIONS</b> . . . . .	10
<b>INDEX</b> . . . . .	11
<b>REFERENCE LIST OF FIGURES</b>	
Figure 1 – Front View . . . . .	1
Figure 2 – Rear View . . . . .	1
Figure 3 – HPCU Pneumatic Schematic . . . . .	2
Figure 4 – Typical PCS 400/HPCU Installation . . . . .	3
Figure 5 – Pressure System Block Diagram . . . . .	4
Figure 6 – Dimensional Outline . . . . .	8

***User's Notes:***

A large rectangular area filled with a grid of small, evenly spaced dotted lines, intended for the user to write notes or observations.

# HIGH PRESSURE CONTROL UNIT

## INTRODUCTION

The Mensor Model 410 High Pressure Control Unit (HPCU) is a secondary pneumatic controller that interfaces with a Mensor PCS 400. Except for the front and rear panels, the HPCU is identical in size and appearance to the PCS 400. The combination of the HPCU and PCS 400 extends precision pressure measurement and control capabilities of the

PCS 400 beyond 1000 psi. Operating the HPCU is very straightforward and does not deviate significantly from that of operating a stand-alone PCS 400. In the CONTROL mode the system automatically switches between the low and high pressure modes as appropriate for the commanded control point.

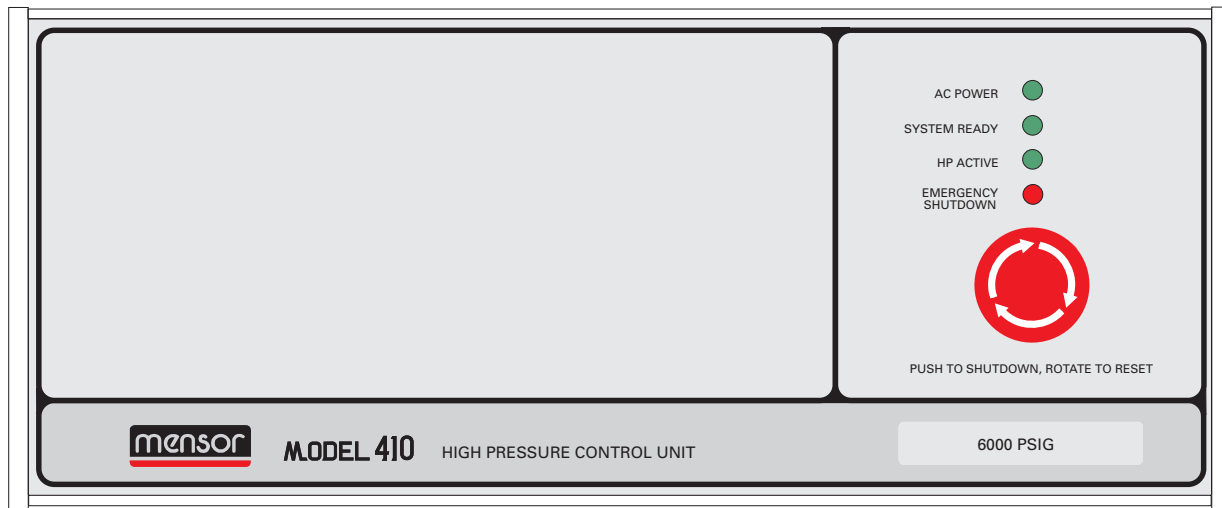

Figure 1 - Front View

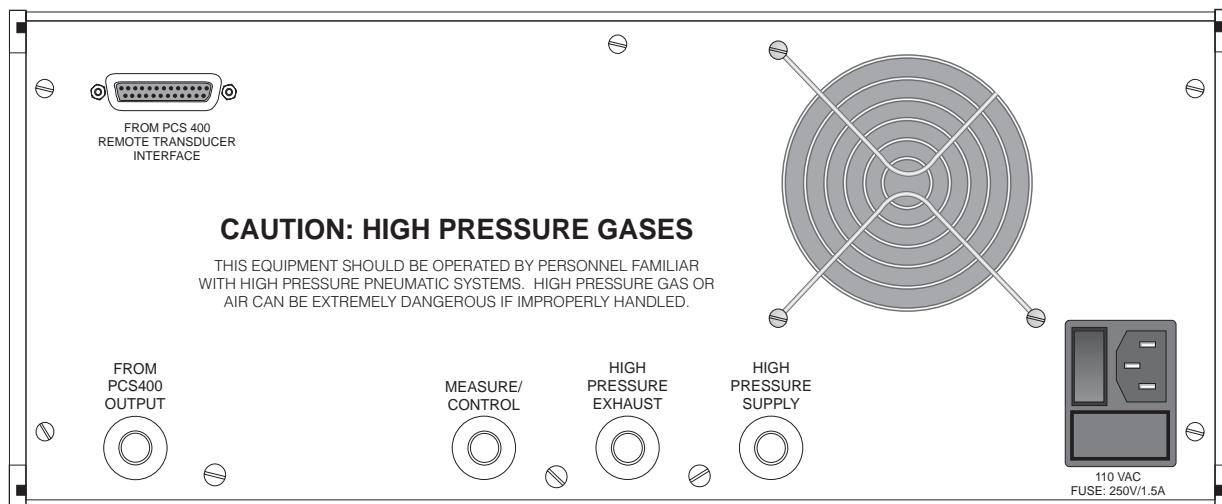
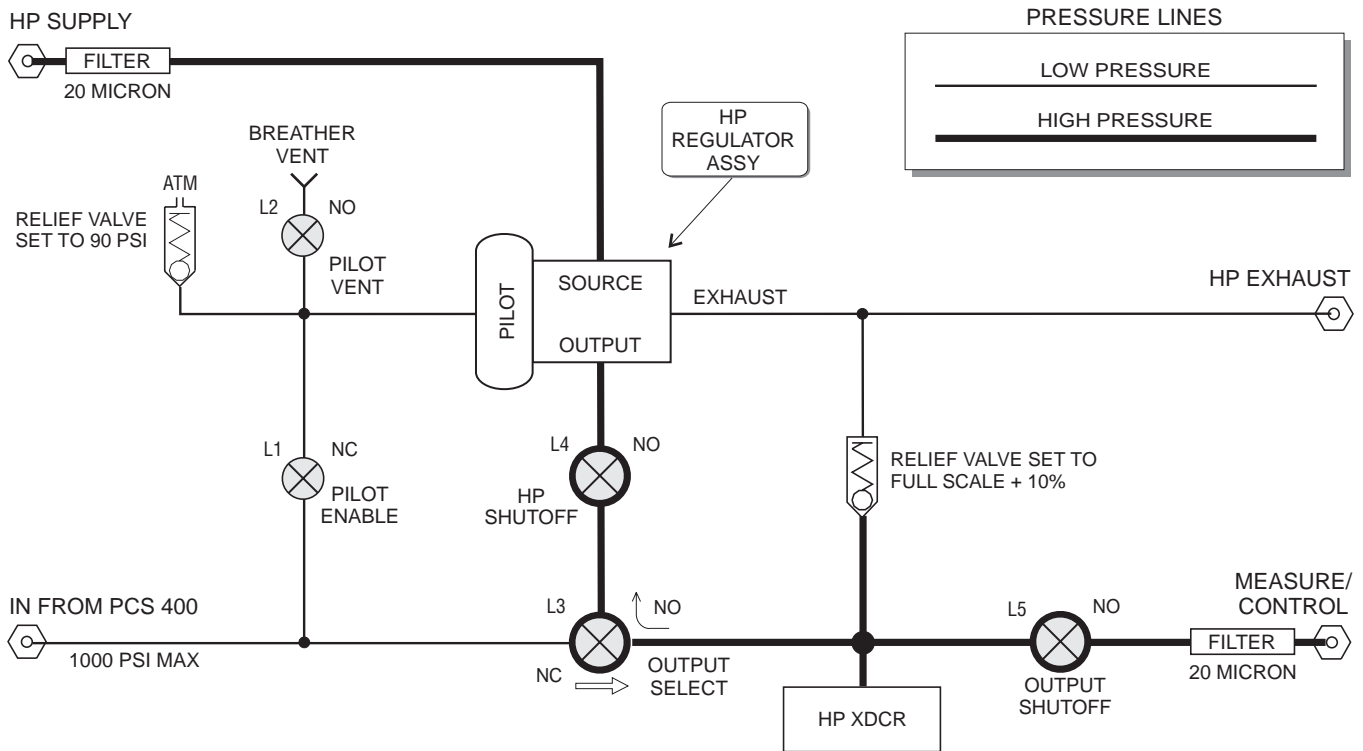

Figure 2 - Rear View

The HPCU uses a pilot operated regulator that is controlled by the PCS 400's internal regulator. High pressure valves are used to switch between low and high pressure modes and to provide measure mode functionality. Low pressure valves route the PCS 400 output to either the HPCU's main output valve or the pilot dome, as required. A high pressure sensor in the HPCU provides feedback for the

control loop. Internal popoff valves provide over-pressure protection for both the HPCU and back to the PCS 400. The HPCU is configured to work with the specific PCS 400 designated as its controller. Do not attempt to use any other PCS 400 to control this device. The HPCU pneumatic schematic is shown in Figure 3.



SOLENOID VALVES

REF	PSI	CONFIG	NORMALLY	SYMBOL
L1	150	2 WAY	CLOSED (NC)	
L2	1000	2 WAY	OPEN (NO)	
L3	6000	3 WAY	OPEN (NO)	
L4	6000	2 WAY	OPEN (NO)	
L5	6000	2 WAY	OPEN (NO)	

NC = NORMALLY CLOSED; NO = NORMALLY OPEN

SOLENOID VALVE TRUTH TABLE

	L1 (NC)	L2 (NO)	L3 (NO PORT) (NC PORT)	L4 (NO)	L5 (NO)
ALL LP MODES	CLOSED	OPEN	CLOSED	OPEN	*
HP VENT & STANDBY	CLOSED	OPEN	OPEN	CLOSED	OPEN
HP MEAS	CLOSED	OPEN	OPEN	CLOSED	CLOSED
HP CONT	OPEN	CLOSED	OPEN	CLOSED	OPEN

\* L5 IS CLOSED ONLY DURING TRANSITIONS BETWEEN LP AND HP CONTROL

Figure 3 - HPCU Pneumatic Schematic

## SAFETY FIRST



**CAUTION: DUE TO ITS WEIGHT, AND THE UNBALANCED DISTRIBUTION OF THAT WEIGHT, THE HPCU SHOULD BE PICKED UP BY TWO PEOPLE OR BY A MECHANICAL LIFTING DEVICE!**



**CAUTION: HIGH PRESSURE GAS CAN BE EXTREMELY DANGEROUS IF IMPROPERLY HANDLED!**

**Please re-read the above caution.** The hazards of improperly handling high pressure gas or air cannot be overstated. It is the operator's responsibility to assure that the tubing and fittings used in the system meet the following conditions:

- must have a working pressure rating equal to or greater than the maximum required pressure
- must be in good mechanical condition, i.e., good threads on fittings, tubing free of kinks or nicks, etc.
- must be properly installed and tightened

When designing the overall pressure system, minimize the total volume external to the HPCU as much as possible. Larger volumes take longer to vent, whether due to an intentional shutdown or a catastrophic failure of some pressure seal or other component. The danger posed by the failure of a system with a larger volume is that it will increase the time it takes for the pressure to fully vent to atmosphere. The venting gas from the HPCU can pose several hazards:

1. The gas used will most likely be an inert gas such as nitrogen. Under conditions of high exhaust flow and confined spaces the oxygen in the immediate vicinity of the exhaust may be displaced, leading to fatigue or even death to those breathing such oxygen deprived atmosphere.
2. Small articles exposed to the escaping gas can be propelled at ballistic speeds to the endangerment of nearby personnel and equipment.
3. Under certain conditions, the noise level created by the gas exiting equipment under high pressure can become dangerously high.

## INSTALLATION

Just like its companion PCS 400, the HPCU is suitable for either bench-top or rack mount installation (see Figure 4). The host PCS 400 must have installed software which is specifically configured for HPCU operation, and the two units must be electrically and pneumatically connected together. Use the supplied interface cable to connect the Remote Transducer port on the rear panel of the HPCU (see Figure 2) to a similar port on the rear of the PCS 400.

The HPCU and PCS 400 must be pneumatically plumbed as shown in Figure 5. Flexible high pressure tubing (standard 6 feet long) and two mating SS fittings (1/4" tube to 7/16 SAE) are provided to connect the MEASURE/CONTROL port of the PCS 400 to the Model 410 port as shown in Figure 5.

When setting up the system be sure to include a vent valve on the high pressure output side of the booster as shown in Figure 5. Boosters normally incorporate an internal one-way flow valve to the downstream volume, and do not provide a way to eliminate this trapped pressure when they are shut down. The vent valve shown in Figure 5 provides a means to bleed off that high pressure before disconnecting from the system.



Figure 4 - Typical PCS 400/HPCU Installation

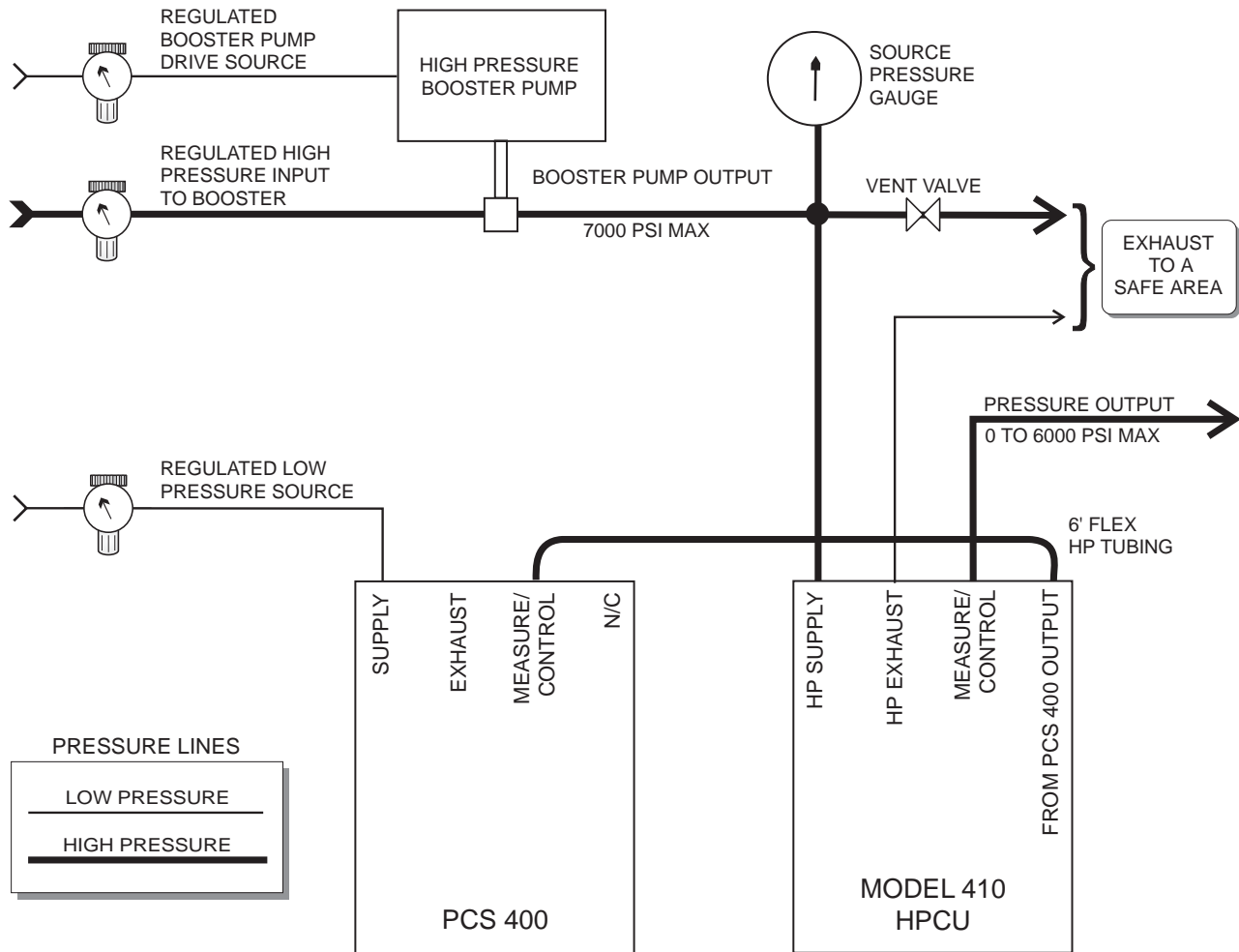

Figure 5 - Pressure System Block Diagram

**MODES OF OPERATION**

The PCS 400/HPCU combination operates in MEASURE, CONTROL and VENT modes just as the PCS 400 does when used alone. The STANDBY mode vents the HPCU high pressure to provide an additional level of safety. Another difference is the identity of the HPCU transducer. In LOCAL operation the HPCU transducer is identified on the PCS 400 display as @HPCU rather than the standard @01 internal transducer identity. In REMOTE operation the HPCU transducer is identified over the bus as

transducer number 8. Also, when switching from the CONTROL mode to any other mode, the current transducer is the one last used for controlling pressure. This means that if the system switched from controlling with the HPCU to the VENT mode, the active transducer would be the high pressure transducer. If the system were controlling within the range of the PCS 400 and then switched to the VENT mode the active transducer would be the PCS 400's internal transducer.



**TEST Mode**

There are no tests that apply to the HPCU.

**GAUGE/ABSOLUTE EMULATION Mode**

When available, use F1 function.

**STANDBY Mode**

If the HPCU is active, selecting the STANDBY mode will cause the HPCU to go to a safe mode by venting the high pressure. The PCS 400 will trap air to maintain the lower pressure drive signal status quo.

**MEASURE Mode**

For pressures within the full scale range of the PCS 400 there is no change to the MEASURE mode functionality as defined in the PCS 400 manual. When the pressure to be measured is above the maximum range of the PCS 400 the HPCU (address 08) must be selected as the active range before the higher pressure is applied to the system.

To select the HPCU as the active range from the PCS 400 keypad go through the LIMITS menu to the "ACTIVE XDCR SETUP" function. Press the [+] or [-] key several times to get to the @08 display, then press [=], and [2nd], [MEAS]. The front panel will reflect that the HPCU is the active range with the message **MEASURED @ HPCU:**, followed by the measured pressure value.

When changing into or out of the MEASURE mode there is a delay of several seconds. This is indicated on the front panel display by a **WAIT...** message. In remote operation a **B** to indicate BUSY is placed at the beginning of the output string. An effect of switching from CONTROL mode to MEASURE mode is that there is a slight loss of pressure in the system.

**CONTROL Mode**

The HPCU is switched into or out of the pneumatic stream by the host PCS 400 depending upon the specified control point. For pressures within the full scale range of the PCS 400 there is no change to the CONTROL mode functionality as defined in the PCS 400 manual. Control points within the range of the PCS 400 use the PCS 400 internal regulator. Control points greater than the full scale range of the PCS 400 cause the system to automatically activate the HPCU without user intervention. The PCS 400 display will indicate the switchover by

showing the HPCU as the active sensor in place of the @01 sensor address. In addition, the "ACTIVE" LED on the front panel of the HPCU will be turned on.

There may be a delay of several seconds as the internal PCS 400 regulator transitions from being the primary controller to being the pilot controller. This is indicated in the PCS 400 display with a **WAIT...** message, or a **B** for BUSY at the beginning of the output string over the remote communications bus.

**NOTE:** *During the transition the output pressure is trapped between whatever is connected to the output port and an internal output shutoff valve while the HPCU drives to the control point. Do not command a new control point during this WAIT period. If in the REMOTE mode, poll the system for a BUSY flag. Send a new control point only when the flag is not invoked. (Refer to the PCS 400 manual for information on REMOTE operation and messages.)*

With the HPCU in CONTROL mode, control within 5% FS of the setpoint must be attained within two minutes after a new setpoint has been commanded. If the two minute window is exceeded the system will switch to VENT and the new control setpoint will have to be re-entered after pressing CE to clear error.

If the PCS 400's internal transducer is selected as the active transducer while the HPCU is in the CONTROL mode one of the following will occur:

- In LOCAL operation, the control point will be set equal to the full scale range of the PCS 400.
- In REMOTE operation, the command is ignored.

There are several safety features and error conditions that are unique to the HPCU's control mode. These are listed under "Safety Features and Error Conditions" in this manual.

**VENT Mode**

There is no change to the VENT mode functionality as defined in the PCS 400 manual.

## MAINTENANCE

There are two 1.5A fuses accessible on the rear panel (1A for optional 230V power). There are no user serviceable parts inside the HPCU. The unit must be returned to Mensor for service.

## SAFETY FEATURES AND ERROR CONDITIONS

The HPCU adds several safety features that are not provided in a standard PCS 400. There are also several additional error conditions relating to the interface with the HPCU. Each of these were included to minimize the risk of working with high pressure gas. These features are no substitute for proper tubing, fittings, and operational technique.

When a safety feature is invoked or an error condition is detected the HP ACTIVE LED on the HPCU will be turned off and the system will go to the VENT mode. Over the remote communications ports an error code is indicated in the same manner as a standard PCS 400, by placing an 'E' at the beginning of the output string. The PCS 400 will not accept any further commands for the HPCU until the error is cleared. HPCU errors take precedence over all other errors (subsequent errors will be ignored until the HPCU error is cleared). An error may be cleared by any of the following four actions:

### Clear Error in Local Operation

1. Press CE on the front panel of the PCS 400.

### Clear Error in Remote Operation

2. Send a `_PCS4 ERR?` command. This will clear the error code and return the error number if an error exists.
3. Perform a Serial Poll Request (SRQ). This will clear the error code and return the error number in hex OR'd with 40 hex.
4. Send a Device Clear (DCL) message. This will clear the error code but gives no indication of what the error was.

It is the operator's responsibility to fully investigate the cause of an HPCU shutdown before attempting to use the HPCU again. Obviously this is impossible if a Device Clear message is issued before determining the error code. If an SRQ is performed, the error code must be read from the status byte and acted upon before any further commands are sent to the

PCS 400. An often overlooked feature of some GPIB software is the automatic SRQ. This can cause errors to be cleared without the operator's direct action. The problem caused by ignoring the error code and continuing to place the HPCU into the CONTROL mode is that the safety features are effectively bypassed.

### Error Code E60 High Pressure Control Unit Off

An error code of E60 can be caused by one or more of the following situations:

1. HPCU Line Power Problem. If none of the LEDs on the HPCU front panel are lit either: 1) the line power cord is not connected to a proper power source; or 2) the HPCU power button on the rear panel is OFF; or 3) the fuse(s) on the rear panel may be blown.
2. Interface Cable Disconnected or Faulty. A problem with the interface cable is indicated if the SYSTEM READY LED is not illuminated.
3. Emergency Shutdown Button Activated. The front panel of the HPCU (see Figure 1) includes an EMERGENCY SHUTDOWN pushbutton and an LED indicator. Pressing this pushbutton while in CONTROL, MEASURE, STANDBY or VENT mode, whether in LOCAL or REMOTE operation, will immediately vent the output pressure and illuminate the EMERGENCY SHUTDOWN LED. The pushbutton must be reset manually by rotating it clockwise to restore the system to other functions. While it is possible to clear the error remotely, the error will be immediately reinstated until the pushbutton is physically reset. After the pushbutton is reset the system will remain in VENT mode until a mode change command is entered.

### Error Code E61 High Press Controller Unit Error

The HPCU will generate an E61 error as a result of one of the following conditions while in the high pressure CONTROL mode:

1. The HPCU sensed inadequate source pressure or an open pressure line on the output; the HPCU was unable to achieve a positive pressure greater than 8% of the control point within five seconds after entry of a control point.

2. The HPCU sensed inadequate source pressure or a leak in the pressure system; the HPCU was unable to achieve a pressure within 5% FS (300 psi @ 6000) of the control point within 2 minutes of entry of a control point.
3. The HPCU sensed a significant leak or broken pressure line, or a change in the system volume; a pressure drop of 200 psi or more occurred after the HPCU came within  $\pm 0.02\%$  FS of the control point.

## REMOTE OPERATION

The remote operation of the HPCU is identical to a standard PCS 400 except as noted previously under 'Modes of Operation' and the two new output formats shown below.

### **\_PCS4 OUTFORM 5**

sp value, value cr lf

The first value is the current pressure in the current engineering units. The second value is the current auxiliary sensor pressure in the current engineering units. Note: the accuracy of the auxiliary sensor is approximately 5% FS.

### **\_PCS4 OUTFORM 6**

sp value, value, stable cr lf

The first value is the current pressure in the current engineering units. The second value is the current control point in the current engineering units. The stable field will contain the string "STABLE" or "UNSTABLE" depending upon the current pressure stable status. This format is useful in read loops while waiting for the instrument to achieve a pressure stable condition. Previously, the user had to send the `_PCS4 STAT?` command to retrieve the stable status. This had a significant affect on control performance because the PCS 400 spent too much time servicing the remote communications relative to the control algorithms. This usually resulted in longer settling times.

## SPECIFICATIONS

The specifications given in the main PCS 400 manual apply to the PCS 400/HPCU combination except as listed in this addendum. Note that the transducer in the HPCU uses a sealed gauge (sg) sensor and therefore some pressure values are listed as 'psisg'. The difference between a gauge sensor and an sg sensor is that a gauge pressure sensor measures pressure using atmospheric pressure as a reference, whereas the reference pressure in an sg sensor is a sealed in 'atmospheric' reference pressure.

### General Specifications

**Dimensions** (see Figure 6 on the following page)

17.05" x 6.97" x 20.50" (43.31cm x 17.70cm x 52.07cm) (WxHxL) without fittings.

19.00" x 6.97" x 20.50" (48.26cm x 17.70cm x 52.07cm) (WxHxL) with rack adapter, without fittings

Add 0.40" (1.02cm) to height for instrument feet.

### Weight

51 lb. (23.13kg).

4.0 lb. (1.81kg) additional for rack adapter kit.

4.0 lb. (1.81kg) additional for 230V power option.

### Power

Standard: 95–130 vac, 50/60 Hz, 60 va max.

Optional: 190-260 vac, 50/60 Hz, 80 va max.

6 ft. 3-wire removable Power Cord.

### Fuses

1.5A, 95 to 125 VAC power (standard).

1A, 190 to 245 VAC power.

### Pressure Ranges (absolute or sealed gauge)

700 to 3000 psi.

700 to 6000 psi.

### Overpressure Rating

110% above full scale range.

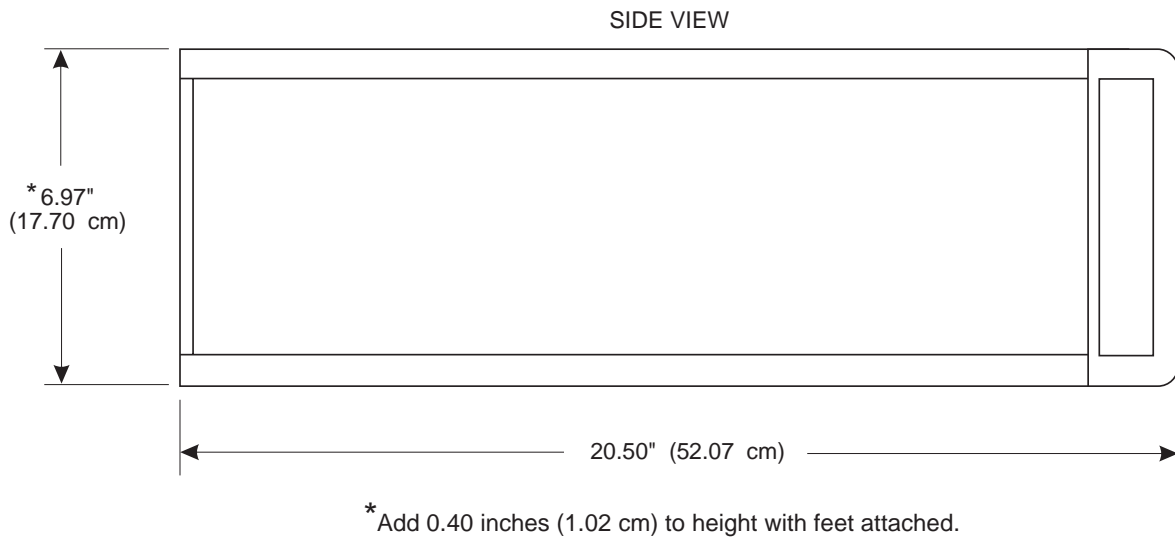
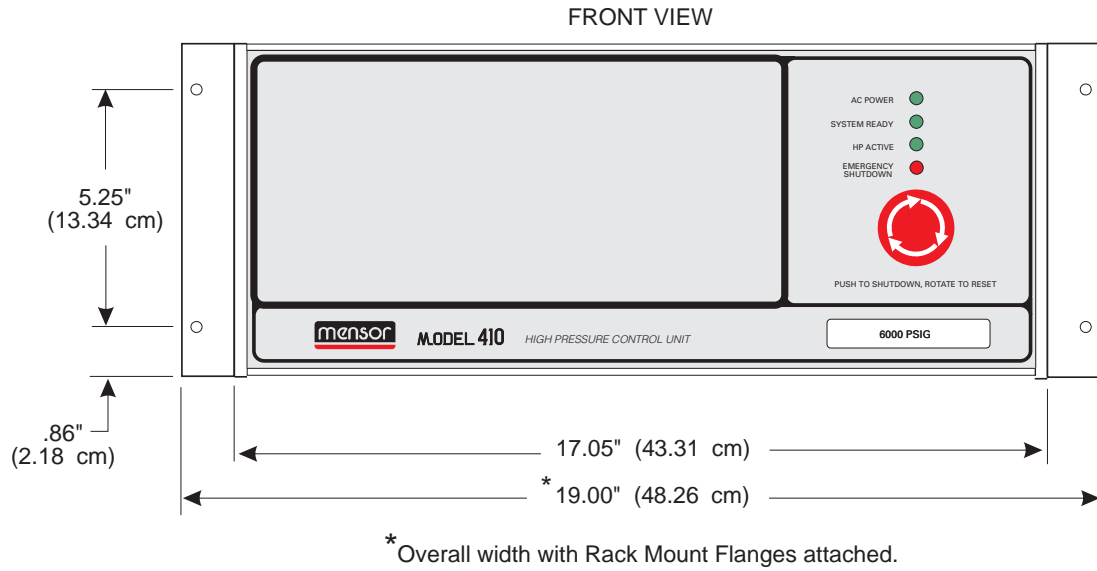

Figure 6 - Dimensional Outline

**Pressure Media**

Clean, dry non-corrosive gases. Not rated for oxygen service.

**Display**

Four LED status indicators.

**Interface Connector**

25 pin female D-sub (standard Centronics parallel printer cable).

**Length of pressure line and Interface Cable between PCS 400 and HPCU**

50 ft max. with a 20 cc external volume.  
Larger volumes require shorter pressure line.  
Standard Interface Cable: 6 ft. long Interface cable provided.

**Gravity/Orientation Effects**

Zero: negligible.  
Span: negligible.  
Linearity: negligible.  
(Negligible = less than 1/2 least significant display digit.)

**Warm-up**

Approximately 30 minutes to rated accuracy.

**Mounting**

Standard: Table Model.  
Optional: Rack Mount with slides for 19 inch rack. (See PCS 400 manual for details).

**Temperature**

Operating temperature range: 0°C - 50°C  
Compensated temp. range: 15°C - 45°C  
Storage temperature range: -20°C - 70°C

**Humidity**

5% to 95% RH non-condensing humidity.

**Pressure Connections**

*Low pressure ports:*  
7/16-20 female SAE/MS\* ports in high strength aluminum block.  
*High pressure ports:*  
7/16-20 female SAE/MS\* ports in stainless steel (300 series) block.  
1/4 FPT stainless steel adapters provided.

\* (per MS16142 and SAE J514 Table 14)

**Communication**

All communications and electrical controls are performed over the Remote Transducer Interface. The PCS 400 MEASURE/CONTROL port controls the Model 410 in response to

commands from the PCS 400's front panel or remote communications ports.

**Measurement Specifications**

**Instrument Uncertainty** (includes combined linearity, hysteresis and repeatability over the compensated temperature range)  
0.025% of full scale (standard).  
0.010% of full scale (optional).

**Measurement Response Time**

Response to full scale pressure step: 0.25 seconds.  
Update rate: 25 to 30 readings per second (minimum).

**Measurement Reading Noise**

Less than 0.01% of full scale.  
(No reading difference greater than  $\pm 0.01\%$  of full scale when 1000 successive readings are taken under static pressure and temperature conditions and in a typical electrical operating environment).

**Calibration Adjustments**

Changes to high pressure transducer zero and span values are made through the PCS 400 front panel or communications ports. Zero and span adjustments are stored in memory on the high pressure transducer. Zero adjustments may be made without affecting the span or linearity. Span adjustments may also be made without affecting the zero or linearity.

**Calibration Stability**

0.010% FS for 180 days after re-zeroing.  
Optional 0.025% FS accuracy instruments are 0.025% for 180 days after re-zeroing.

**Control Specifications****Source Pressure (HPCU only)**

Full scale range 6% to 10%.

**Stability of Control Pressure (HPCU only)**

0.02% full scale maximum with a 20 cc external volume.

Typically better than 0.01% after 30 seconds at pressure stable.

**Dynamic control response time with a 20 cc external volume (HPCU only) \***

30 seconds to within 0.1% full scale.  
60 seconds to within 0.02% full scale (default pressure stable).

Any transition between PCS 400 and HPCU: additional 15 seconds to above time limits (PCS 400 specifications apply when the control point is within the PCS 400's range).

**Control Timeout**

A 'Stable Control' signal indicates that controlled pressure is held to within 0.02% of FS for 16 seconds. If control pressure has not been achieved within two minutes of commanding a pressure control point the system will default to VENT mode.

**External Volume**

0 to 300 cc. Larger volumes require a shorter pressure line between the PCS 400 and HPCU, and the Dynamic Control Response times will be longer.

**Internal Controlled Pneumatic Volume**

55 cc; Add 10 cc for high pressure input to the Tescom regulator.

**Minimum Control Pressure (HPCU only)**

700 psi or PCS 400 highest range + 0.01 psi (the PCS 400 is used below this pressure).

**Pressure Rate Mode (HPCU only)**

Not available in high pressure mode.

**Pressure Overshoot (HPCU only) \***

Typically 1.5% maximum with up to 20cc external volume.

\* The dynamic control response time and the pressure overshoot is dependent upon the capacity and performance characteristics of the source pressure supply (booster). Low supply capacity will lengthen the upscale response time. Pressure overshoot can be affected by pressure surges from the source.

**OPTIONS**

230 VAC input power.  
Extra Operation Manual.  
Interface cable: 3 or 10 ft.  
(6 ft. is standard).  
Flexible high pressure tubing: 4 or 8 ft.  
(6 ft. is standard).  
Supply pressure booster.  
Extended warranty.  
On-site installation and training.  
Rack mount kit.

**INDEX**

<b>A</b>		
Active Xdcr Setup . . . . .	5	
Auxiliary Sensor Pressure . . . . .	7	
<b>B</b>		
Block Diagram, Pressure System . . . . .	4	
Boosters . . . . .	3, 4	
<b>C</b>		
Cable, Interface . . . . .	3, 9	
Calibration Adjustments . . . . .	9	
Calibration Stability . . . . .	9	
Communication . . . . .	9	
Connector, Interface . . . . .	9	
Connections, Pressure . . . . .	9	
Control Mode . . . . .	1, 4, 5	
Control Specifications . . . . .	9, 10	
Control Timeout . . . . .	10	
<b>D</b>		
Device Clear (DCL) . . . . .	6	
Dimensions . . . . .	7, 8	
Display . . . . .	9	
<b>E</b>		
Emulation Mode, Gauge/Absolute . . . . .	5	
Emergency Shutdown . . . . .	6	
Error Codes/Conditions . . . . .	6	
<b>F</b>		
Fittings . . . . .	3, 9	
Front View . . . . .	1	
Fuses . . . . .	1, 6, 7	
<b>G</b>		
Gauge/Absolute Emulation Mode . . . . .	5	
Gravity/Orientation Effects . . . . .	9	
<b>H</b>		
Humidity . . . . .	9	
<b>I</b>		
Identity, HPCU Transducer . . . . .	4	
Installation . . . . .	3	
Interface Cable . . . . .	3, 9	
Interface Connector . . . . .	6, 9	
Introduction . . . . .	1	
<b>L</b>		
Leak . . . . .	7	
LED's . . . . .	5, 6, 9	
Active . . . . .	5	
Emergency Shutdown . . . . .	6	
<b>M</b>		
Maintenance . . . . .	6	
Measure Mode . . . . .	5	
Modes of Operation . . . . .	4 - 5	
Mounting . . . . .	3, 9	
<b>N</b>		
Noise, Reading . . . . .	9	
<b>O</b>		
Operation, Remote . . . . .	7	
Options . . . . .	10	
Overpressure Protection . . . . .	2	
Overpressure Rating . . . . .	7	
Overshoot . . . . .	10	
<b>P</b>		
Pneumatic Schematic . . . . .	2	
Port, Measure/Control . . . . .	3	
Port, Remote Transducer . . . . .	3	
Power . . . . .	7	
Pressure Connections . . . . .	3, 9	
Pressure Lines . . . . .	2	
Pressure Media . . . . .	9	
Pressure Ranges . . . . .	7	
<b>R</b>		
Reading Noise . . . . .	9	
Rear View . . . . .	1	
Regulator . . . . .	2	
Remote Operation . . . . .	4, 5, 7	
Response . . . . .	9	
<b>S</b>		
Safety . . . . .	ii, 3	
Safety Features and Error Conditions . . . . .	6	
Serial Poll Request (SRQ) . . . . .	6	
Source Pressure . . . . .	6, 9	
Specifications . . . . .	7 - 10	
Stability . . . . .	9	
Standby Mode . . . . .	4, 5	
<b>T</b>		
Temperature Specifications . . . . .	9	
Test Mode . . . . .	5	
Tubing . . . . .	3, 9	
<b>U</b>		
Uncertainty, Instrument . . . . .	9	
<b>V</b>		
Valves . . . . .	2, 3	
Vent Mode . . . . .	4, 5	
Volume . . . . .	3, 9, 10	
<b>W</b>		
WAIT . . . . .	5	
Warm-up . . . . .	9	
Warnings, Health and Safety . . . . .	ii, 1, 3, 6	
Warranty . . . . .	ii	
Weight . . . . .	7	
<b>Z</b>		
Zero and Span Adjustments . . . . .	9	



MENSOR CORPORATION  
201 BARNES DRIVE  
SAN MARCOS, TEXAS 78666-5994

Phone: 512.396.4200  
Fax: 512.396.1820  
Web site: [www.mensor.com](http://www.mensor.com)  
E-mail: [sales@mensor.com](mailto:sales@mensor.com)