



Operation Manual - PN 0011470001 D2
DPG II BAROMETER - MODEL 14500



CODE _____

SN _____

MENSOR CORPORATION
201 BARNES DRIVE
SAN MARCOS, TEXAS 78666-5994
Phone: 512.396.4200
Fax: 512.396.1820
Web site: www.mensor.com

WARRANTY

All products manufactured by Mensor[®] Corporation are warranted to be free of defects in workmanship and materials for a period of one year from the date of shipment. No other express warranty is given, and no affirmation of Seller, by words or actions, shall constitute a warranty. SELLER DISCLAIMS ANY IMPLIED WARRANTIES OF MERCHANTABILITY OR FITNESS FOR ANY PARTICULAR PURPOSES WHATSOEVER. If any defect in workmanship or material should develop under conditions of normal use and service within the warranty period, repairs will be made at no charge to the original purchaser, upon delivery of the product(s) to the factory, shipping charges prepaid. If inspection by Mensor Corporation or its authorized representative reveals that the product was damaged by accident, alteration, misuse, abuse, faulty installation or other causes beyond the control of Mensor Corporation, this warranty does not apply. The judgment of Mensor Corporation will be final as to all matters concerning condition of the product, the cause and nature of a defect, and the necessity or manner of repair. Service, repairs or disassembly of the product in any manner, performed without specific factory permission, voids this warranty.

MENSOR CORPORATION MAKES NO WARRANTY OF ANY KIND WITH REGARD TO THIS MANUAL, INCLUDING, BUT NOT LIMITED TO, THE IMPLIED WARRANTIES OF MERCHANTABILITY AND FITNESS FOR A PARTICULAR PURPOSE. Mensor Corporation shall not be liable for errors contained herein or for incidental or consequential damages in connection with the furnishing, performance, or use of this material.

WARNINGS AND CAUTION NOTES

WARNING: NOT EXPLOSION PROOF! Installation of this instrument in an area requiring devices rated as intrinsically safe is not recommended.

CAUTION: USE THE PROPER PRESSURE MEDIUM. USE ONLY CLEAN, DRY NON-CORROSIVE GASES. THIS INSTRUMENT IS NOT DESIGNED FOR OXYGEN USE.

CAUTION: AS WITH MOST SENSITIVE ELECTRONIC EQUIPMENT, SWITCH THE POWER SWITCH OFF BEFORE CONNECTING OR DISCONNECTING TO A POWER SOURCE TO PREVENT DATA LOSS

	<p>CAUTION: ESD PROTECTION REQUIRED. The proper use of grounded work surfaces and personal wrist straps are required when coming into contact with exposed circuits (printed circuit boards) to prevent static discharge damage to sensitive electronic components.</p>
--	--

PLEASE NOTICE...

The product specifications and other information contained in this manual are subject to change without notice.

Mensor Corporation has made a concerted effort to provide complete and current information for the proper use of the equipment. If there are questions regarding this manual or the proper use of the equipment, contact Mensor Corporation at:

TEL	1-512-396-4200 or 1-800-984-4200 (USA only)
FAX	1-512-396-1820
WEB SITE	http://www.mensor.com
E-MAIL	sales@mensor.com tech_support@mensor.com

PACKAGING FOR SHIPMENT

If the product must be shipped to a different location or returned to Mensor for any reason through a common carrier it must be packaged properly to minimize the risk of damage.

The recommended method of packing is to place the instrument in a container, surrounded on all sides with at least four inches of shock attenuation material such as styrofoam peanuts.

TRADEMARKS

Mensor is a registered trademark of Mensor Corporation. All other brand and product names are trademarks or registered trademarks of their respective companies.

©1997, Mensor Corp. All rights reserved.

SOFTWARE LICENSE AGREEMENT

This product contains intellectual property, i.e., software programs, that are licensed for use by the end user/customer (hereinafter "End User").

This is not a sale of such intellectual property.

The End User shall not copy, disassemble or reverse compile the software program.

THE SOFTWARE PROGRAMS ARE PROVIDED TO THE END USER "AS IS" WITHOUT WARRANTY OF ANY KIND, EITHER EXPRESS OR IMPLIED, INCLUDING, BUT NOT LIMITED TO, WARRANTIES OF MERCHANTABILITY AND FITNESS FOR A PARTICULAR PURPOSE. THE ENTIRE RISK OF THE QUALITY AND PERFORMANCE OF THE SOFTWARE PROGRAM IS WITH THE END USER.

MENSOR AND ITS SUPPLIERS SHALL NOT BE HELD TO ANY LIABILITY FOR ANY DAMAGES SUFFERED OR INCURRED BY THE END USER (INCLUDING, BUT NOT LIMITED TO, GENERAL, SPECIAL, CONSEQUENTIAL OR INCIDENTAL DAMAGES INCLUDING DAMAGES FOR LOSS OF BUSINESS PROFITS, BUSINESS INTERRUPTION, LOSS OF BUSINESS INFORMATION AND THE LIKE), ARISING FROM OR IN CONNECTION WITH THE DELIVERY, USE OR PERFORMANCE OF THE SOFTWARE PROGRAM.

TABLE OF CONTENTS

Warranty	ii
FCC Radio Frequency Emission Note	ii
Warnings and Caution Notes	iii
Please Notice	iii
Packaging for Shipment	iii
Trademarks	iv
Software License Agreement	iv
1. INTRODUCTION	
Did you get Everything?	1-1
Initial Inspection	1-1
Meet your Model 14500	1-1
Power Up!	1-2
2. SYSTEM CONFIGURATION	
Front Panel 1/+ Switches	2-1
Measurement Units	2-3
GPIB Address	2-5
Test Modes	2-7
Output Resolution	2-8
Display Configuration	2-8
3. INSTALLATION	
Mounting	3-1
Pressure Connection	3-1
Power On	3-1
Error Conditions and Suggested Actions	3-2
4. LOCAL OPERATION	
Standard Displays	4-1
Custom Displays	4-1
Hourly Barometric Change	4-2
Sea Level Adjust	4-3
Altitude	4-4

5. REMOTE OPERATION

GPIB	5-1
Device Address	5-2
Service Request	5-2
Local Lockout	5-2
Status Display	5-2
GPIB Interface Messages	5-2
DCL	5-2
GET	5-3
GTL	5-3
IFC	5-3
LLO	5-3
SDC	5-3
Serial Poll	5-3
Device Dependent Messages	5-4
Expanded Message Set	5-4
Terse Message Set	5-11
Altitude	5-16

6. MAINTENANCE AND CALIBRATION

Maintenance	6-1
Calibration	6-2
Calibration Environment	6-1
Calibration Standards	6-2
Calibration Medium	6-2
Calibrating the DPG II Barometer	6-2
Local Zero Adjustment	6-4
Local Span Adjustment	6-4
Remote Zero Adjustment	6-4
Remote Span Adjustment	6-5
Correction Value Query	6-6

7. SPECIFICATIONS

Ranges	7-1
Pressure Medium	7-1
Uncertainty	7-1
Transducer	7-1
Digital Output	7-2
Analog Output	7-2

Calibration Standard	7-2
Measurement Error Due to Temperature Change	7-2
Altitude Pressure Units and Local Elevation Correction	7-2
Hourly Barometric Change	7-2
Compensated Temperature Range	7-2
Output Resolution	7-3
Optional Outputs	7-3
Response Time	7-3
Warm-up	7-3
Over Pressure Rating	7-3
Attitude Error	7-3
Operating Environment	7-3
Shipping, Storage and Handling Environment	7-4
Outputs	7-4
Display	7-4
Power	7-4
Fuse	7-4
Mounting	7-4
Pressure Connection	7-4
Size	7-5
Weight	7-6
Transducer Volume (Cubic Centimeters)	7-6

8. OPTIONS

Rechargeable Battery Pack	8-2
Battery Charger	8-3
Automotive Power Cord	8-3
Rack Mount Kit	8-3
Handles	8-4
Carrying Handle	8-4
Tilt Stand/Carrying Handle	8-4
Carrying Cases	8-5
EIA-232 Serial Communication Port	8-6
EIA-232 Switch Settings (Communication Board)	8-7
Analog and BCD Output	8-9
Analog Output	8-9
BCD Output	8-10

9. APPENDIX

TABLE 9.1 - Conversion Factors, psi 9-2
 TABLE 9.2 - Conversion Factors, millitorr 9-4
 TABLE 9.3 - Temperature Conversion Table 9-6
 TABLE 9.4 - Materials in Contact with Pressure Medium 9-7
 Head Pressure Correction 9-8
 TABLE 9.5 - Gas Density 9-8
 Head Pressure Calculation 9-9
 FIGURE 9.1 - Head Pressure Calculation 9-9
 TABLE 9.6 - Std. Sea Level Press. at Various Elevations 9-10
 TABLE 9.7 - Pressure Offsets at Various Elevations 9-11
 TABLE 9.8 - Chassis DIP Switches 9-12
 FIGURE 9.2 - EIA-232 Cable Connections 9-13
 TABLE 9.9 - Quick Reference List of Commands 9-14
 Sample IEEE Program 9-16

10. GLOSSARY 10.1

11. INDEX 11.1

Reference List of Figures

1.1 - Front View 1-3
 1.2 - Rear View (Standard) 1-3
 2.1 - Printed Circuit Boards 2-2
 2.2 - Switch Configuration Display 2-8
 6.1 - Calibration Setup 6-3
 7.1 - Dimensional Outline 7-5
 8.1 - Battery Pack 8-2
 8.2 - Rack Mount Diagram 8-3
 8.3 - Handles 8-4
 8.4 - Carrying Case 8-5
 8.5 - Communication Board 8-6
 8.6 - Rear Panel (Analog and BCD Output) 8-9
 8.7 - Analog/BCD Output Board 8-11
 9.1 - Head Pressure Calculation 9-9
 9.2 - EIA-232 Cable Connector 9-13
 10.1 - Pressure Relationships 10-8

Reference List of Tables

2.1 - Standard Measurement Units 2-3
2.2 - Units Selection 2-4
2.3 - Setting the GPIB Address 2-5
2.4 - Test modes 2-7
3.1 - Error Conditions and Suggested Actions 3-2
5.1 - The 'Q' Command Data/Output Format 5-13
5.2 - The 'U' Command Syntax for Measurement Units 5-14
7.1 - Additional Uncertainty of Altitude/Feet 7-2
8.1 - EIA-232 Switch Functions and Settings 8-7
8.2 - Baud Rate 8-7
8.3 - Analog/BCD Output Pin Assignments 8-10
8.4 - Units Codes 8-12
8.5 - Decimal Codes 8-12
9.1 - Conversion Factors, psi 9-2
9.2 - Conversion Factors, millitorr 9-4
9.3 - Temperature Conversion 9-6
9.4 - Materials in Contact with Pressure Medium 9-7
9.5 - Gas Density 9-8
9.6 - Standard Sea Level Pressure at Various Elevations 9-10
9.7 - Pressure Offsets at Various Elevations 9-11
9.8 - Chassis DIP Switches 9-12
9.9 - Quick Reference List of Commands 9-14

User's Notes:

A large rectangular area filled with a grid of small, dotted lines, intended for the user to write notes. The grid consists of approximately 20 columns and 30 rows of squares.

INTRODUCTION

DID YOU GET EVERYTHING?

In addition to this manual you should have:

- DPG II Model 14500
- 12 vdc power module
- An installed 1/8 inch NPT fitting adapter with filter
- Any accessories ordered
- Envelope containing
 - Certificate of Compliance
 - Calibration Chart
 - Warranty Certificate

INITIAL INSPECTION

In addition to the many hours of functional testing, your *DPG II* was inspected at the factory for dings, dents and scratches. Please examine it now for signs of shipping damage. Report any apparent damage to the carrier immediately.

MEET YOUR MODEL 14500

The Model 14500 Barometer is a high accuracy pressure measurement instrument which functions either manually (LOCAL), or from a computer (REMOTE). The front panel includes the power switch, a 2-line by 16-character display, a pressure units selection switch, and the -/+ adjustment switches. See figure 1.1.

The standard rear panel includes the 12 vdc power connector, the pressure connection port, the IEEE-STD-488 port, a cutout for an optional interface port and eight configuration switches for setting certain conditions. See figure 1.2.

There are additional configuration switches mounted internally that were set at the factory according to the customer's requirements. All 'as shipped' internal and rear panel switch settings for the Main Board are recorded in figure 2.1 in the *System Configuration* section of the manual.

The instruction set that runs the instrument is programmed into firmware (IC U5) on the Main Board. The program version number is shown on a label affixed

to the chip, and is also shown in figure 2.1 in the *System Configuration* section of the manual.

The Silicon Pressure Transducer (SPT) is an integrated assembly consisting of a precision silicon sensor, a fitting block, the signal conditioning electronics, and a sheet metal bracket tying them together to form a module. The SPT module is screwed down to the Main Board and to the rear panel. The output of the SPT is a modified signal derived from a micromachined wafer of silicon which responds to pressure. The proprietary modification produces a device with exceptional repeatability and stability over time within a broad temperature band.

POWER UP!

You can confirm that your Barometer is operational right now. Simply apply 12V dc to the power connector on the rear of the gauge and push the front panel power switch ON. The display will come on and go through an initialization procedure. The unit will step through a series of screens beginning with three views of pixel tests. These are quickly followed in order by the displays shown below:

Exception to the above is that SERIAL might be either BCD, DAC/BCD, or blank if none of these options are included. Also, the EIA/BAUD screen will appear only if the serial interface option is installed.

```
MODEL 14500
RATE SERIAL
```

```
MENSOR DPG II
VERSION 3.10
```

```
MENSOR DPG II
SN: 290111
```

```
MENSOR DPG II
34.0000 INHG A
```

```
MENSOR DPG II
 GPIB ADDRESS: 01
```

```
EIA-232-C
9600 BAUD 7/1/N
```

```
CALIBRATE
A/D
```

```
XX.XXXX PSI A
BARO. PRESS.
```

For the last screen, with no pressure connected, the Barometer will display atmospheric pressure in the measurement units that were specified when the instrument was ordered. This confirms that the *DPG II* is ready for work. If this is your first time to use a *DPG II* please review the Warnings and Cautions information on page iii. Then take the time to familiarize yourself with the *Installation* and *Operation* sections of this manual as you go.

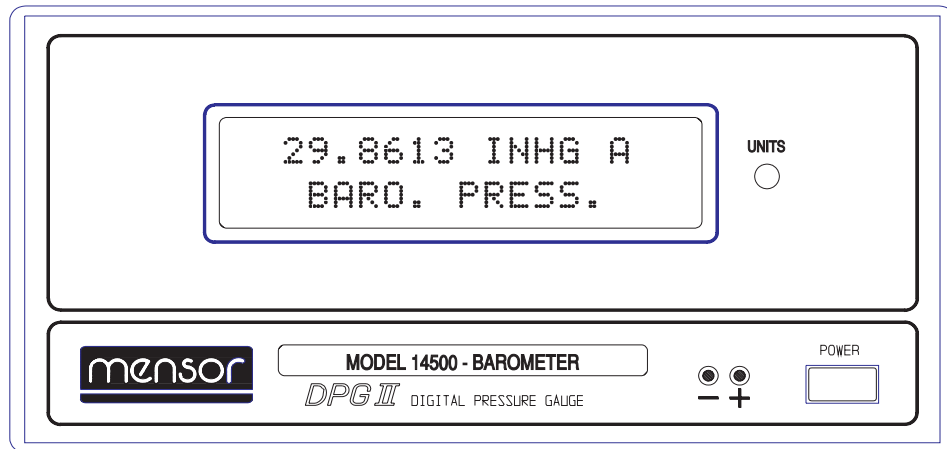

Figure 1.1 - Front View

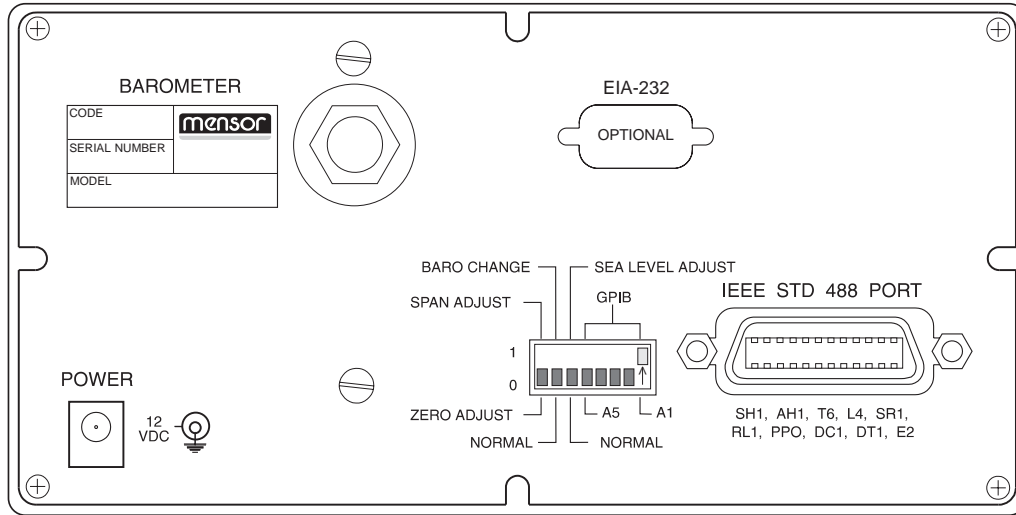

Figure 1.2 - Rear View (Standard)
 (See *Options* section for Analog/BCD output rear panel)

SYSTEM CONFIGURATION

The configuration switches in this instrument were set at the factory for the pressure units and options, as ordered. The initial setting for each Main Board switch is illustrated in Figure 2.1. No further changes are required for the gauge to function. The user may choose other switch settings, as explained later, to set the following:

- Select ZERO or SPAN mode for front panel – and + switches
- Enter sea level correction
- Display hourly barometric change
- Change output resolution
- Set GPIB address
- Select secondary measurement units
- Enable test modes
- Set up EIA-232 serial communications Port (see *Options* section)

FRONT PANEL –/+ SWITCHES

The two front panel switches marked – and + are used to adjust either the zero or the span settings of the *DPG II* (and sea level corrections). Rear panel switch S2-1 and one internal switch determines which parameter is affected by the –/+ switches. A full explanation of how these switches operate is included in the ‘Calibration’ portion of the *Maintenance and Calibration* section.

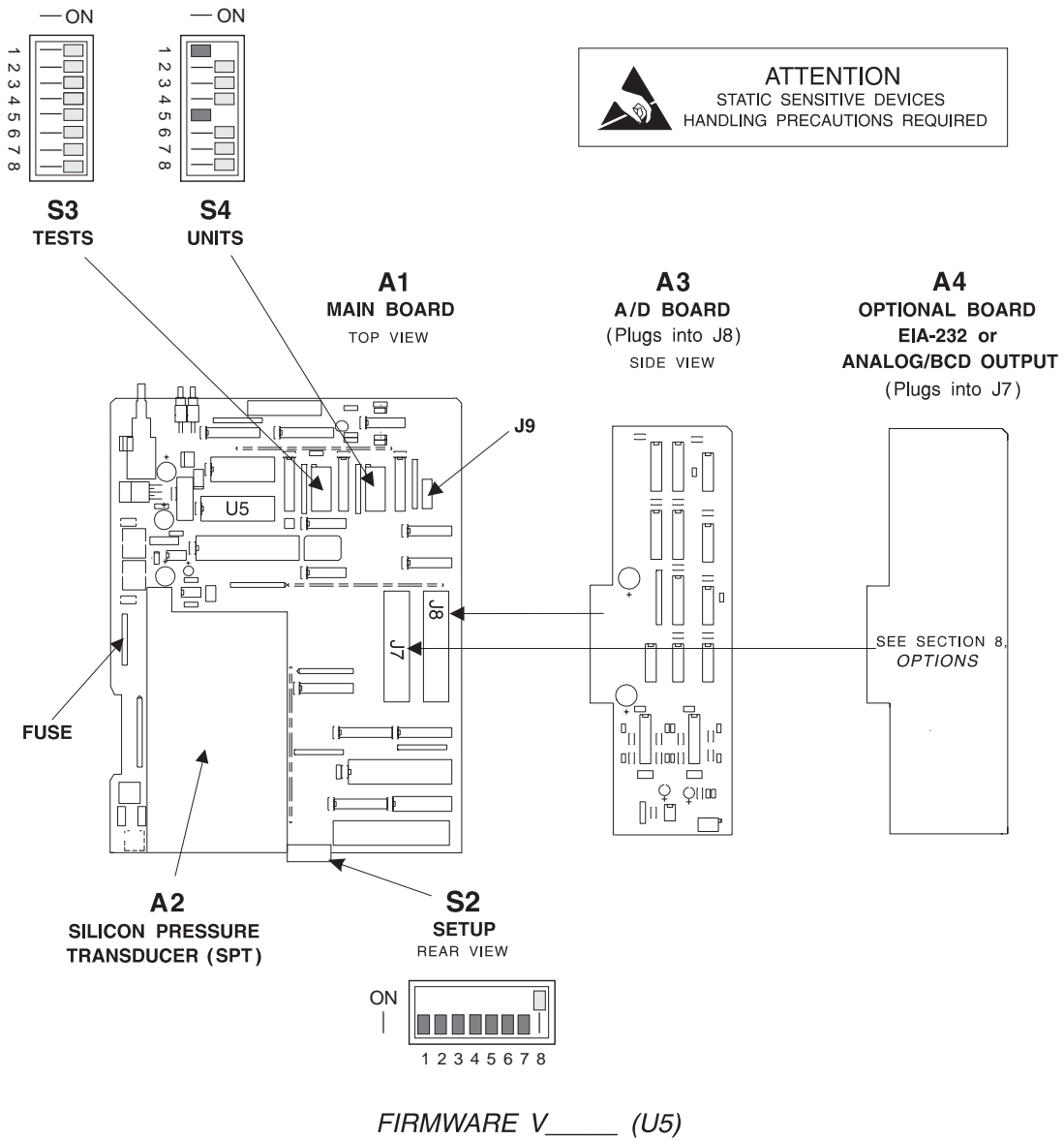

Figure 2.1 - Printed Circuit Boards

MEASUREMENT UNITS

The Barometer can output the pressure reading in any of the measurement units listed in table 2.2. The conversion factors used internally to convert from psi to the other measurement units are listed in table 8.1 in the *Appendix*.

A front panel switch located to the right of the display provides the means to manually select from a menu of pre-set engineering units. Pressing the switch will display the current engineering unit. Holding the switch for approximately 2 seconds will begin incrementing through the menu which consists of eight pre-set units. The Barometer will be active in the units that are displayed when the switch is released.

The standard units loaded into the menu at the factory are seen in table 2.1, below. The first of the eight units (menu item one) is always psi. The second item is determined by the settings of configuration switches S4-2 through S4-8 as shown in table 2.2. (The location of S4 is shown in figure 2.1).

The last six units (menu items 3 through 8) are optional, and can be set to any of the measurement units of table 2.2 by means of a remote bus. The **E** (Engineering Units) Command in the *Remote Operation* section explains the procedure for loading, changing or deleting menu items 3 through 8 over the GPIB or over an optional EIA-232 bus.

Table 2.1 – Standard Measurement Units

Menu	Units	Re-set Method
1	psi	Base units – not re-settable
2	inH ₂ O @ 4°C	Set alternate units by configuring S4-2 through S4-8
3	inHg @ 0°C	Remove or change units for menu lines 3 through 8 by re-loading over a remote bus.
4	hPa	
5	mBar	
6	Torr	
7	mmHg @ 0°C	
8	kPa	

Note that the factory may have loaded other measurement units into menu items 2 through 8 in response to a customer request at the time the instrument was ordered.

Table 2.2 – Units Selection (/ indicates OFF)

Units Code	Units	S4-2	S4-3	S4-4	S4-5	S4-6	S4-7	S4-8
1	psi	ON	/	ON	ON	ON	ON	ON
2	inHg @ 0°C	ON	ON	/	ON	ON	ON	ON
3	inHg @ 60°F	ON	/	/	ON	ON	ON	ON
4	inH ₂ O @ 4°C	ON	ON	ON	/	ON	ON	ON
5	inH ₂ O @ 20°C	ON	/	ON	/	ON	ON	ON
6	inH ₂ O @ 60°F	ON	ON	/	/	ON	ON	ON
7	ftH ₂ O @ 4°C	ON	/	/	/	ON	ON	ON
8	ftH ₂ O @ 20°C	ON	ON	ON	ON	/	ON	ON
9	ftH ₂ O @ 60°F	ON	/	ON	ON	/	ON	ON
10	mtorr	ON	ON	/	ON	/	ON	ON
11	in seawater	ON	/	/	ON	/	ON	ON
12	ft seawater	ON	ON	ON	/	/	ON	ON
13	atm	ON	/	ON	/	/	ON	ON
14	bars	ON	ON	/	/	/	ON	ON
15	mbars	ON	/	/	/	/	ON	ON
16	mm H ₂ O @ 4°C	ON	ON	ON	ON	ON	/	ON
17	cm H ₂ O @ 4°C	ON	/	ON	ON	ON	/	ON
18	m H ₂ O @ 4°C	ON	ON	/	ON	ON	/	ON
19	mm Hg @ 0°C	ON	/	/	ON	ON	/	ON
20	cm Hg @ 0°C	ON	ON	ON	/	ON	/	ON
21	torr	ON	/	ON	/	ON	/	ON
22	kPa	ON	ON	/	/	ON	/	ON
23	Pa	ON	/	/	/	ON	/	ON
24	dynes/cm ²	ON	ON	ON	ON	/	/	ON
25	g/cm ²	ON	/	ON	ON	/	/	ON
26	kg/cm ²	ON	ON	/	ON	/	/	ON
27	m seawater	ON	/	/	ON	/	/	ON

Continued on next page...

Units Code	Units	S4-2	S4-3	S4-4	S4-5	S4-6	S4-7	S4-8
28	oz/in ²	ON	ON	ON	/	/	/	ON
29	psf	ON	/	ON	/	/	/	ON
30	tsf	ON	ON	/	/	/	/	ON
31	%FS	ON	/	/	/	/	/	ON
32	mHg @ 0°C	ON	ON	ON	ON	ON	ON	/
33	tsi	ON	/	ON	ON	ON	ON	/
34	hPa	ON	ON	/	ON	ON	ON	/
* 40	feet (altitude)	ON	ON	ON	ON	/	ON	/
* 41	meters (altitude)	ON	/	ON	ON	/	ON	/

* If altitude units are enabled (codes 40 or 41) the hourly barometric change feature will be disabled.

GPIB ADDRESS

Switches S2-4 through S2-8 on the rear panel will set the GPIB address per the following table. To make a change, power OFF, set the switches, then power ON. (/ indicates OFF.)

Table 2.3 – Setting the GPIB Address

GPIB Address	S2-4	S2-5	S2-6	S2-7	S2-8
0	/	/	/	/	/
1	/	/	/	/	ON
2	/	/	/	ON	/
3	/	/	/	ON	ON
4	/	/	ON	/	/
5	/	/	ON	/	ON
6	/	/	ON	ON	/
7	/	/	ON	ON	ON
8	/	ON	/	/	/

Continued on next page...

GPIB Address	S2-4	S2-5	S2-6	S2-7	S2-8
9	/	ON	/	/	ON
10	/	ON	/	ON	/
11	/	ON	/	ON	ON
12	/	ON	ON	/	/
13	/	ON	ON	/	ON
14	/	ON	ON	ON	/
15	/	ON	ON	ON	ON
16	ON	/	/	/	/
17	ON	/	/	/	ON
18	ON	/	/	ON	/
19	ON	/	/	ON	ON
20	ON	/	ON	/	/
21	ON	/	ON	/	ON
22	ON	/	ON	ON	/
23	ON	/	ON	ON	ON
24	ON	ON	/	/	/
25	ON	ON	/	/	ON
26	ON	ON	/	ON	/
27	ON	ON	/	ON	ON
28	ON	ON	ON	/	/
29	ON	ON	ON	/	ON
30	ON	ON	ON	ON	/
31 (not valid)	ON	ON	ON	ON	ON

TEST MODES

Certain diagnostics are automatically performed at initialization. In addition to the self-tests, several other tests can be performed by setting internal switches S3-1 through S3-4 (on the Main Board) per Table 2.4, below. **Conversion Rate** displays the reading update rate currently being used by the *DPG II*. **Dual A/D** is a mode that displays the raw pressure and the temperature outputs of the analog-to-digital converters for factory use. The last test, **Switches**, terminates the test procedures, and displays a graphic of all switch settings as currently configured, for S2 on the rear, and S3 and S4 on the main board (see figure 2.2). The rest of the tests are self explanatory. (/ indicates OFF.)

Table 2.4 – Test Modes

Test Mode	S3-1	S3-2	S3-3	S3-4
Normal Operation	ON	ON	ON	ON
RAM	/	ON	ON	ON
Display	ON	/	ON	ON
Ports	/	/	ON	ON
Conversion Rate	ON	ON	/	ON
Dual A/D (for factory use)	/	ON	/	ON
S/N	ON	/	/	ON
Range	/	/	/	ON
GPIB Address	ON	ON	ON	/
Switches (see figure 2.2)	/	/	/	/

To reset to another test, power down, set the switches for the desired test, then power up. Upon completion of all tests, reset S3-1 thru S3-4 to ON for normal operation.

The carets (^) in figure 2.2 (next page) indicate switch 1 on S2, S3 and S4.

See figure 2.1 for the location and orientation of these three switches which are mounted on the main board.

NOTE: Switch positions shown are for illustration purposes, only, and are not intended to reflect your instrument.

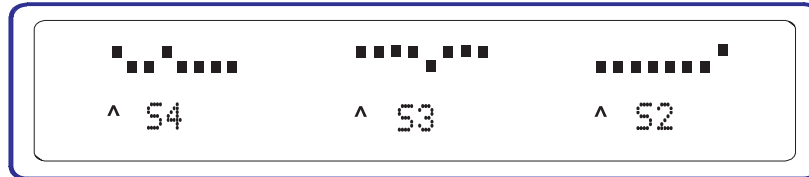

Figure 2.2 - Switch Configuration Display

OUTPUT RESOLUTION

Internal switch S4-1 on the Main Board can be set for standard resolution (ON), or high resolution, (OFF). Depending on the currently selected engineering units, the maximum resolution in standard mode is one part in 50,000, and in high resolution the maximum is one part in 500,000. Instruments normally are shipped with S4-1 set for high resolution output. High resolution can present a very nervous least significant digit for some ranges. In such cases switching to standard resolution will provide a more readable display.

NOTE: The Barometer must be turned off before changing S4-1.

DISPLAY CONFIGURATION

The display is normally configured for standard pressure readings as seen in figure 1.1. The bottom line (BARO. PRESS.) can be replaced with an 'hourly Barometric change' reading by placing switch S2-2 on the rear panel (see figure 1.2) to ON (up).

In addition, the top and bottom lines of the display can be transposed as explained under 'CUSTOM DISPLAY' in the *Local Operation* section, or the bottom line 'BARO. PRESS.' display can be replaced by a custom message entered by the operator using the **C** Command as explained in the *Remote Operation* section of this manual. All references to top and bottom display lines in this manual refer to the standard configuration unless otherwise stated.

INSTALLATION

The *DPG II* combines the precision of a laboratory instrument with the ruggedness of a field meter. It will perform equally well on a table top, mounted in a rack, or in the field as a portable, battery powered instrument. See *Options* for details on rack adapters, carrying handles and battery packs.

MOUNTING

The special sensor used in the Barometer is relatively insensitive to tilt and vibration. However, to further assure stability and accuracy, excessive vibration of the mounting surface should be avoided.

PRESSURE CONNECTION

The pressure port on the transducer is vented to atmosphere and comes with a 1/8 NPT adapter fitting and a simple screen filter installed. If desired, a pressure source can be connected to the 1/8 inch adapter by removing the filter and attaching the proper NPT hardware. Or, the 1/8 inch adapter can also be removed exposing the female threads of the transducer which are 7/16-20 SAE/MS straight threads per MS16142 and SAE J514 table 14. This opening requires a tube fitting boss seal with an o-ring adapter per MS33656. When connections to a pressure source are made, use a thread sealant such as Loctite Hydraulic Sealant or fresh teflon tape on the male NPT threads. (Do not use thread sealant on fittings that are sealed with an o-ring). The integrity of the seal is particularly important since even microscopic leaks can cause errors in pressure measurements. A leak test is recommended after all connections are made.

NOTE: When making up connections to the o-ring adapter use a back-up wrench to prevent over-stressing the threads in the aluminum block.

POWER ON

With the *DPG II* either vented to atmosphere or connected to a pressure source, and power connected to the rear of the gauge, push the power switch ON. The gauge will go through a brief initialization process and system check. If a failure is detected, an error message will appear in the display. See Table 3.1 which follows and take the suggested action. If no errors are detected, the gauge is ready to use.

ERROR CONDITIONS AND SUGGESTED ACTIONS

Table 3.1 – Error Conditions And Suggested Actions

Error	Hex	Dec	Description	Suggested Action
00	0	0	No error	
01	41	65	RAM data error	Contact Mentor.
02	42	66	RAM battery is low	Contact Mentor.
03	43	67	Stack over/underflow	Contact Mentor.
04	44	68	Command syntax error	Check the command string for extra or incorrect characters.
05	45	69	Invalid parameter	Check the numeric parameter to see if it is in the valid range.
06	46	70	Input buffer overflow	Too many characters were sent before an X was received. Resend.
07	46	71	Output buffer overflow	Send command and read it back to keep buffer empty.
08	48	72	GPIB bus error	A problem has been detected with the GPIB control lines. Check the controller and cables for proper connection.
09	49	73	Not used	Contact Mentor.
10	4A	74	Display fault	The display cannot be updated. Contact Mentor.
11	4B	75	A/D fault	Contact Mentor.
12	4C	76	Calibration access error (for factory use)	An unauthorized attempt was made to enter the coefficients. Contact Mentor.
13	4D	77	Illegal switch code	One of the setup switches (probably S4, units selection) is set incorrectly. Check S4.
14	4E	78	Range too low for altitude engineering units	Range <14.4 psi. Change units.

Continued on next page...

Error	Hex	Dec	Description	Suggested Action
15	4F	79	Number > 1 million	Contact Mensor.
16	50	80	Calculation overflow	Power up, send GPIB commands Z0X, S0X, N1X, N5X, then power OFF and back ON. This sequence clears the zero and span offsets, and average readings. Otherwise, contact Mensor.
17	51	81	Division by zero	Contact Mensor.
18	52	82	EIA-232 receiver overrun	73 characters received w/o X. Resend.
19	53	83	EIA-232 framing error	Check all switch settings of S1 and S2 on the optional Communications Board, then resend.
20	54	84	EIA-232 parity error	Parity incorrect if enabled. Check and resend.
21	55	85	Attempting to monitor hourly change when units are in feet or meters, or when in sea level adj.	Change units, disable sea level adj, or disable hourly change monitor.
22	56	86	Not used	Contact Mensor.
23	57	87	Not used	

User's Notes:

A large rectangular area filled with a grid of small, evenly spaced dotted lines, intended for the user to write notes or instructions.

LOCAL OPERATION

The *DPG II* has two operating modes, LOCAL, which is hands-on, and REMOTE, which is from a computer over a communication bus. The LOCAL mode of operation for a standard instrument is covered in this section. REMOTE operation is covered in the next section (Section 5). Section 6, *Maintenance and Calibration*, provides information on performing specific calibration procedures both in the local and the remote modes, while Section 8, *Options*, gives details on non-standard operating modes for the various optional features.

With the Barometer configured as explained in the *System Configuration* section, the following features and functions are available from the front and rear panels except as noted.

STANDARD DISPLAY

In NORMAL mode the top line displays the pressure in the measurement units selected during system configuration. (See 'Measurement Units' in the *System Configuration* section to change the displayed units). The bottom line will display one of the following messages:

BARO. PRESS.	normal display.
BARO. PRESS. RT	if GPIB talker is enabled.
BARO. PRESS. RL	if GPIB listener is enabled.
ERROR:##	for error indication.

CUSTOM DISPLAY

The top and bottom lines of the display can be transposed such that the bottom line appears on top, and the top line appears on the bottom. To transpose the two lines remove the rear panel screws and slide the Main board assembly out the rear of the case. Locate header J9 (see figure 2.1) on the main board and use the spare shunt provided there to connect pins 5 and 8. The display can be restored to normal operation by removing the shunt.

As an additional feature the bottom line of the instrument can be customized to suit the user. This can be accomplished only over the GPIB bus (REMOTE) using the custom range display command. Refer to 'C Command' in the *Remote Operation* section of the manual for details.

HOURLY BAROMETRIC CHANGE

NOTE: This feature is disabled if feet or meters are the active measurement units (units codes 40 or 41).

The Hourly Barometric Change function calculates the hourly change in barometric pressure. This function is always active, but is seen on the display only if rear panel switch S2-2, BARO CHANGE, is ON (up).

The Barometric Change function uses a special tracking buffer to store 60 pressure readings which are one-minute running averages. If this function is enabled at power up the following sequence of events will occur:

The buffer is cleared during initialization, then immediately begins accumulating the average pressures over one minute intervals. During the first two one-minute pressure readings the bottom line of the display will show **?????? /HRe**.

After the second minute, and for the remainder of the first hour, the instrument bottom line will display **snnnnnnn /HRe** where:

s = arithmetic sign
nnnnnnn = calculated value up to seven digits
/HR = per hour, and
e indicates the value is an estimate.

(example: **+0.123 /HRe**)

During this first hour the estimated value is calculated by the formula:

$$(\text{current reading} - \text{1st reading}) * 60 / (\text{reading number} - 1).$$

At the end of the first hour each additional reading received by the buffer displaces the oldest reading stored there. The displayed value is then the difference between the latest one minute average and the oldest one minute average. The display will drop the **e** (estimate) and update the hourly change each minute thereafter using the formula:

$$(\text{current reading} - \text{oldest buffer value})$$

Note that the buffer and the calculations continue to operate at all times while power is applied, except when altitude units (unit codes 40 and 41) are active. Switching the BARO CHANGE switch ON merely sends the results to the display.

SEA LEVEL ADJUST

Sea level barometric readings can be corrected for local elevation with the SEA LEVEL ADJUST feature. To enter the correction value first check that the current units are pressure units. SEA LEVEL ADJUST will not work if the instrument is set to units of altitude (feet or meters). Next, set rear panel switch S2-3 to SEA LEVEL ADJUST (up) to enable the front panel + and – switches and change the bottom line of the display to read SEA LEVEL. In this mode when either the + or – switch is pressed the top line of the display will read **SEA LEVEL ADJ:**, and the bottom line will indicate the current elevation as corrected.

Hold either of the two switches down for more than one second to cause the least significant digit to begin incrementing or decrementing. Continue to hold the switch until the display has reached the correct value for the local elevation.

The elevation units will display in feet if the selected engineering units are English, or in meters for metric engineering units. Table 5.2 shows which units are English and which are metric. The adjustment resolution is one unit, either foot or meter. The adjustment range is from 3000 feet below sea level (–3000 ft) to 30,000 feet above sea level (+30000 ft). To reset the corrected elevation to zero (sea level) press both the + and the – switches and release them simultaneously.

Once the local elevation is entered, the Barometer converts the value to an equivalent pressure using the equation:

$$\text{InHg} = (\text{FT} - 145447.2) / - 76189.042) ^ 5.2561$$

The calculated value for local elevation is then algebraically added to a reading equivalent to sea level, yielding a sea level offset. This offset is then combined with the reading from the SPT and the result is output to the display and the remote bus.

Table 9.6 in the *Appendix* shows the calculated values at various elevations, and table 9.7 gives the pressure offsets for the same elevations and units.

NOTES:

1. Switching S2-3 to SEA LEVEL ADJUST (up) overrides the ZERO and SPAN adjusting functions of the front panel + and - switches.
2. Switching S2-3 to NORMAL (down) returns the Barometer to standard display. However, switching S2-3 back to SEA LEVEL ADJUST will cause the display to output a pressure corrected to the elevation last entered.
3. SEA LEVEL ADJUST will not work if units are in feet or meters.

ALTITUDE

The Barometer can measure pressure in equivalent feet or meters of altitude from -3000 to 100,000 feet. For accurate altitude output the current measurement units must be either feet or meters, the Sea Level Adjustment feature must be OFF, and the sea level correction value in memory must be zero.

See the 'Sea Level Adjust' text under 'Local Operation' to manually re-zero after a sea level correction has been entered. Then switch the Sea Level Adjust feature OFF (switch S2-3 set to NORMAL), and set the UNITS to either feet or meters. The equivalent altitude will appear on the display.

For REMOTE operation send **L0X** to re-set the sea level correction to zero and, if the Sea Level Adjustment feature is active, send **LNX** to turn it off. Then set the units to feet or meters with the **U** command (see Table 5.2). The output will be altitude, and can be displayed on the remote screen by sending the query **Q0X**.

NOTE: *The uncertainty of the measured altitude output is given in table 7.1 under Specifications. The uncertainties shown in the table are in addition to the other specified uncertainties.*

REMOTE OPERATION

The *DPG II* can be operated from a remote computer which communicates over the IEEE-488-STD General Purpose Interface Bus, commonly referred to as GPIB. The computer must contain a GPIB card and must be connected to the *DPG II* with a standard IEEE-488 cable.

Software to install and operate the GPIB is provided by the manufacturer of the GPIB card, along with programming examples. The commands listed in this section are the bare commands seen by the *DPG II*, stripped of all programming idioms. Depending on the specific programming language used, it may be necessary to precede or enclose these commands in various symbols for transmission. A brief BASIC program has been included in the *Appendix* for your convenience, as an example.

For additional information on GPIB operation the complete IEEE-488-STD specification is available from the Institute of Electrical & Electronics Engineers Inc., 345 East 47th Street, New York, New York, 10017.

As options, the *DPG II* can be equipped with an EIA-232 serial port, a BCD output or an analog output (see the *Options* section for details).

GPIB

The *DPG II* responds to device dependent commands and GPIB interface commands. The IEEE capability codes are:

- SH1 full source handshake capability
- AH1 full acceptor handshake capability
- T6 talker with serial poll and unaddress if MLA
- L4 listener with unaddress if MTA
- SR1 full service request capability
- RL1 full remote/local capability including LLO
- PPO no parallel poll capability
- DC1 full device clear capability
- DT1 full device trigger capability
- E2 tri-state outputs

DEVICE ADDRESS

The primary address of the *DPG II* on the GPIB is set using the rear panel switch S2 as described in the *System Configuration* section. When the *DPG II* detects a change in the address switches the new address is displayed for approximately one second.

SERVICE REQUEST

The service request line on the GPIB (SRQ) will be asserted when an error is encountered. See the *Installation* section for a table of the possible error conditions and the suggested actions. If the controlling GPIB handler has automatic serial polling, and this feature is enabled, any errors will be cleared.

LOCAL LOCKOUT

When the *DPG II* is in the REMOTE mode, local lockout (LLO) is in effect. The instrument will not respond to any configuration switches changed manually until returned to the LOCAL mode.

STATUS DISPLAY

The *DPG II* indicates the status of the GPIB in the lower right corner of the display, where R=Remote, RL=Listener, RT=Remote Talker, and T=Talker only (LLO not invoked).

GPIB INTERFACE MESSAGES

GPIB interface messages are standardized commands that are a function of the GPIB interface itself. These messages do not apply in any way to serial communications.

The method of sending an interface message to the *DPG II* is dependent upon the specific computer and interface hardware and software being used. The differences occur primarily in the syntax used to invoke the desired command, particularly among different programming languages. Any GPIB controller (i.e., a computer with a GPIB card) should have available the messages defined in this section. They may, however, be identified differently in the actual programming implementation.

DCL

The DEVICE CLEAR (DCL) command is used to reset the internal functions of all devices on the GPIB that respond to this command. All input and output buffers are cleared and the *DPG II* is forced into the REMOTE mode when it receives a DCL. See also SDC.

GET

The GROUP EXECUTE TRIGGER (GET) is used to synchronize the acquisition of data between several instruments connected to the GPIB. When the *DPG II* receives a GET the current GPIB output reading is latched until it is read over the bus. The *DPG II* display will continue to update.

GTL

The GO TO LOCAL (GTL) command places the *DPG II* into the LOCAL mode. This will allow the user to change the engineering units, resolution, etc. with the configuration switch on the rear panel (S2). The *DPG II* does not respond to any switch changes while in the REMOTE mode.

IFC

The INTERFACE CLEAR (IFC) command halts all current operations on the bus.

LLO

The LOCAL LOCKOUT (LLO) command prevents LOCAL operation of the instrument. The *DPG II* always has LLO enabled when the unit is in the REMOTE mode.

SDC

SELECTED DEVICE CLEAR (SDC) is similar in function to DEVICE CLEAR (DCL) except that only the device addressed to listen is reset. If the *DPG II* address is selected it immediately goes into REMOTE mode.

Serial Poll

A SERIAL POLL is a high level function of the GPIB interface used to read the status byte of one particular device. Some GPIB interface manufacturers provide this as an automatic function, reading the most recent status byte from the instrument after each read or write instruction. Others require the user to specifically program the GPIB to do a SERIAL POLL of a device.

A common use of the SERIAL POLL is in a program module designed to respond to the service request (SRQ) line on the GPIB. Many GPIB interface manufacturers

provide a way to check the status of the SRQ line. If it is asserted, some instrument on the bus requires service. The service may involve simply acknowledging a change in an instrument's status, completion of an internal function of the instrument, or may indicate the existence of an error. The status byte returned by the serial poll will determine the required service. In the case of the *DPG II* the status byte will always read 0 (zero) unless an error condition exists. Refer to Section 3, *Installation*, for a table of error codes and the suggested action if an error message occurs.

DEVICE DEPENDENT MESSAGES

Device dependent messages are commands or queries specific to the *DPG II* that are sent via a remote port (GPIB or EIA-232). These messages are device dependent since they may not be valid for any other equipment. The *DPG II* includes two types of device dependent messages: a), the terse command set which has been in use from the inception of the *DPG II*; and b), an expanded command set introduced with version 3.10 software. Some of the messages in the expanded set invoke the same response as an equivalent message from the terse set. However, several new capabilities have been added with the expanded messages. Either set of commands can be used, or they can be mixed.

All of the available messages, the transmission format and their purpose are presented below. The newer, expanded messages are given first, in alphabetical order, followed by the older (terse) message set, also in alphabetical order. A QUICK REFERENCE of all of the messages is provided in table 9.9 in the *Appendix*. All of the messages included in both sets are usable, and can be freely intermixed. Notice that all of the messages are insensitive to case, i.e., upper and lower case characters are interpreted the same by the *DPG II*.

Expanded Message Set

The complete listing of the usable messages added with version 3.10 software is given below. When sending a message from the expanded set to the *DPG II* over the GPIB, the last character of the message must trigger an EOI to end the message. A terminating line feed (<lf>) and/or carriage return (<cr>) is allowed, but is not required. Each message heading below is shown in output string format. The basic command is shown in all capital letters and the required or returned variable is represented by lower case characters.

DEFAULT

This command sets the default values for the *DPG II*.

The default values are:

Filter window	0.0025% full scale
Filter percent	90%
Tare	0.0 (Off)
Display	Pressure (normal)
Passwords.	On
Output format	0
Digits	6

DIGITS d (new command)

The digits command sets the bus and display output resolution to five or six digits

where **d** is:

5	for five digits, or
6	for six digits of resolution

DIGITS?

The digits query returns the number of digits in the output resolution. The *DPG II* returns: **d<cr><lf>**

where **d** is: **5** or **6**, same as above

DISPLAY c (similar to **T** command)

This command sets the display format

where **c** is:

0	normal (same as D0 or T0 command)
3	hourly change (same as D5 or T5 command)

DISPLAY?

This query will return: **c<cr><lf>**

Where **c** is: **0** to **5**, same as above.

DOC? (new query)

The DOC query returns the Date Of Calibration for the latest factory calibration as: **mm/dd/yy<cr><lf>**

ERROR? (same as Q4X)

This query will return either a two digit error code (see table 3.1),
or: **NO ERROR<cr><lf>**

FILTER f (new command)

The filter command sets the percentage of exponential filtering applied to the pressure readings

where **f** is: **0** to **99** percent filter

FILTER?

This query returns two characters for the current percentage of exponential filtering as: **f<cr><lf>**

where **f** is two digits: **00** to **99** percent applied filter

ID? (same as Q2X)

The ID query returns the four essential identity characteristics of the instrument such as: **MENSOR, DPG II, ssssss, v.vv<cr><lf>**

where ssssss is: Instrument serial number
where v.vv is: Software version number

MASTER_CAL_ENABLE (new command)

This is a password required to reset the span calibration factor over the bus. Sending this password also allows access to set the zero and tare offset values. The password requirement is turned off when this command is sent, and remains off until one of the following commands is issued: DEFAULT, DCL (device clear) or SDC (selected device clear), or until the next power-up. Any of these actions re-instate the requirement for the password before the span calibration can be changed.

OPT? (new query)

The OPT query returns a list of the installed options
as: **MODEL mmmmm [,rrrr][,com]<cr><lf>**

where mmmmm is: **14000** Quartz Pressure Transducer (QPT)
14500 Precision Barometer
15000 Silicon Pressure Transducer (SPT)
16500 Quartz Resonant Transducer (QRT)

rrrr is: blank

com is: **SERIAL** if EIA-232 option is installed
BCD if BCD output option is installed
DAC/BCD . . . if the Analog output is included
with the BCD output option
or blank

RANGENEG? (similar to **Q3X**)

This query will return the lower limit of the range in psi. This is normally zero, except that a bi-directional unit will return a negative value.

where **-10.000** is: -10 psi

RANGEPOS? (similar to **Q3X**)

This query will return the upper limit the of the range in psi

where **100.000** is: 100 psi

SEA_LEVEL_ENABLE (function reserved for Model 14500 Barometer)

This is a password to enable access to the Sea Level offset. Once it is issued it remains in effect until a DEFAULT, DCL or SDC is received, or until the next power-up.

SEA_LEVEL s (function reserved for Model 14500 Barometer)

This command must be preceded by either the SEA_LEVEL_ENABLE or the MASTER_CAL_ENABLE password before the first occurrence of the SEA LEVEL s command. This command is used to insert a local elevation correction for barometric pressure readings.

where **s** is: a value in feet if english units, or
a value in meters if in metric units

SEA_LEVEL? (function reserved for Model 14500 Barometer)

Returns the elevation correction as: **s<cr><lf>**

where **s** is: Same as above

SPAN s (similar to **S command**)

This command requires the MASTER_CAL_ENABLE command (password) be issued first for the SPAN s command to take effect. SPAN s corrects the pressure reading at full scale. Send the true pressure value (s) while maintaining at least 50% of the FS pressure on the pressure port

where **s** is: true pressure in current engineering units

Notice the difference between this command and the older, abbreviated S command. The older command dealt with span as an offset, that is, the difference between the factory calibration full scale value and the desired full scale value. The newer SPAN s command takes as it's parameter the desired value at the current pressure. The expanded SPAN? query returns the multiplier used to arrive at the desired value.

Examples for a 15 PSIG unit:

Older S command:

```
Send "S0X"  
Pressurize unit to 15.0000 PSIG  
Unit reads: 15.0002 PSIG  
Send "S-0.0002X"  
Unit now reads: 15.0000 PSIG  
Send "S?X"  
Unit responds: -.0002<cr><lf>
```

New SPAN command:

```
Pressurize unit to 15.0000 PSIG  
Unit reads: 15.0002 PSIG  
Send "MASTER_CAL_ENABLE" (send EOI)  
Send "SPAN 15.0000" (send EOI with last character)  
Unit now reads: 15.0000 PSIG  
Send "SPAN?" (send EOI with last character)  
Unit responds: 0.999987<cr><lf>
```

Either command or query will be accepted, and the DPG will return values appropriate to the type of command or query it receives.

SPAN?

The Span query will return the span correction scale factor as: **s<cr><lf>**

where **s** is: a value from **0.90000** to **1.10000**
(see example under "New SPAN command" above)

TARE_CAL_ENABLE (new command)

This is a password to enable access to the Tare offset. Once it is issued it remains in effect until a DEFAULT, DCL or SDC is received, or until the next power-up.

TARE t (new command)

This command must be preceded by either the TARE_CAL_ENABLE or the MASTER_CAL_ENABLE password before the first occurrence of the TARE t command. TARE t sets the tare offset

where **t** is: a value between +/- 17 psi

TARE?

This query returns the current tare calibration variable as: **t<cr><lf>**

where **t** is: current tare offset in current engineering units

TYPE? (new query)

Returns the type of pressure sensor in the instrument

as: **ABSOLUTE<cr><lf>** for an absolute pressure sensor
or **GAUGE<cr><lf>** for a gauge pressure sensor

UNITS u (same as U command)

This command selects the engineering units to be output on the bus and display for all subsequent pressure readings

where **u** is: **0** to **47** from the Units Codes in Table 5.2

UNITS?

This query will return the units code and the ASCII string for the units
as: **01,PSI<cr><lf>**

UNITS_TABLE? (new query)

This query will return the current table of up to eight engineering units stored in the register for the front panel UNITS switch

Terse Message Set

The following device dependent messages include the original terms enabled for the *DPG II*. Most of these terms have an equivalent message in the above, expanded message list. When sending a terse message to the *DPG II*, transmit the message followed by an X. The X signals the *DPG II* to execute the command contained in the message.

C Command (no equivalent expanded command)

The **C** command is used to customize the range display on the *DPG II*. The new message must be 1 to 14 alpha (upper case only), numeric and/or some symbol characters. The message will be left justified, and unused characters will be blanked to the right. The command format is: **CdaaaaaaaaaaaaaadX**

where:

C or **c** = custom range display command
d = delimiter: square brackets ([]).
a = capital letters, numbers and symbols
(except ? or []) making up the new message
to be displayed.

Examples:

1. Replace standard display of " 30.0000 FS" with " 15.0000 FS"
Send: **C[15.0000 FS]X**
2. Replace standard display of " 500.000 FS" with " A COMPANY NAME"
Send: **C[A COMPANY NAME]X**

To return the unit to normal display send: **C[]X**

D or T Command (Barometric Change)

Sending **D5X** or **T5X** over the bus enables the hourly barometric change feature. The functional description of this feature was provided in the *Local Operation* section. To turn off the barometric change issue **DOX** or **TOX**.

E Command (no equivalent expanded command)

As stated under 'Measurement Units' in Section 2, *System Configuration*, the E command is used to re-load the last six of the eight engineering units that are switch-selectable from the front panel of the *DPG II*. These six units (3 through 8) were set at the factory to the customer's request, or were left empty.

To change any or all of these six units send **Enn,nn,nn,nn,nn,nnX**

where: **nn** = a desired unit code from the **U** Command table (table 5.2)

or: **nn** = 99 to eliminate a unit from the list. Sending a series of six 99s would shorten the list to two units: 1 = psi; and 2 = as configured by switches S4-2 through S4-8.

NOTE: *nn* can be either one or two characters. For example, sending either 5 or 05 over the bus would set that units slot to inches of water @ 20°C (INH20 @ 20°C).

Q Command (similar to some expanded commands)

The **Q** command is a request for data from the *DPG II*. The output data will be formatted according to the specific form of the **Q** command. Output formats 0 and 1 will remain selected until changed by a subsequent **Q** command. Output formats 2 through 7 will be in effect for one output cycle only, after which the format will revert to 0 or 1, whichever was last being used.

The syntax for the **Q** command is **QnX** where **n** is a number (0 through 7) as described in table 5.1. The table also lists the resulting output format for each value of **n**.

- space = an ASCII space character (32 dec)
- <cr> = an ASCII carriage return (13 dec)
- <lf> = an ASCII linefeed (10 dec)
- EOI (End Of Instruction) is set with the <lf> (on the GPIB)

Table 5.1 – The ‘Q’ Command Data/Output Format

n	Description	Output Format
0	Pressure reading in the selected units. This is the default output format.	NNNNNNN <cr><lf> where each N is a number (0 through 9), +, -, decimal point, or a space. If the pressure rate or peak monitor option is being used the output format is NNNNNNN,NNNNNNN <cr><lf> . The data before the comma is the pressure and the data after the comma is the pressure rate or peak.
1	Raw A/D readings (for factory use)	nnnnnnn,nnnnnnn <cr><lf> where each n is a number (0 through 9) or a space.
2	Unit ID	MENSOR, DPG II, nnnnnn, n.nn <cr><lf> where each n is a number (0 through 9) in ASCII code representing the unit serial number and the firmware version of the unit.
3	Pressure range and measurement units	NNNNNNN,NNNNNNN, @@@@ @ <cr><lf> where each N is a number (0 through 9), decimal point, or a space and each @ is an alpha-numeric character. The output string represents the minimum pressure, maximum pressure and the pressure units.
4	Error status code	Enn <cr><lf> where each n is a number (0 through 9) representing the error status.
5	Calibration data	Factory use, only.
6	Pressure rate or peak	Not applicable to the precision Barometer.
7	Zero and span corrections	ZZZZZZZ,SSSSSSS <cr><lf> where ZZZZZZZ is the zero correction and SSSSSSS is the span correction.
8	Calibration coefficients	Factory use, only.

Note: The Q1X command changes the output units to counts, and Q0X resets it to default units.

S Command (same as SPAN command)

See *Maintenance and Calibration*, Section 6.

U Command (same as UNITS command)

The **U** command selects the measurement units to be output on the bus and the display.

The syntax for the **U** command is **UnX** where **n** is a number as described in table 5.2.

Table 5.2 – The ‘U’ Command Syntax for Measurement Units

n	Description	Output Format	Type
0	internal counts	COUNTS	RAW DATA
1	pounds per square inch	PSI	ENGLISH
2	inches of mercury @ 0°C	INHG	
3	inches of mercury @ 60°F		
4	inches of water @ 4°C	INH ₂ O	
5	inches of water @ 20°C		
6	inches of water @ 60°F		
7	feet of water @ 4°C	FTH ₂ O	
8	feet of water @ 20°C		
9	feet of water @ 60°F		
10	millitorr	MTORR	METRIC
11	inches of sea water	INSW	ENGLISH
12	feet of sea water	FTSW	
13	atmospheres	ATM	
14	bars	BAR	METRIC
15	millibars	MBAR	
16	millimeters of water @ 4°C	MMH ₂ O	
17	centimeters of water @ 4°C	CMH ₂ O	
18	meters of water @ 4°C	MH ₂ O	

Continued on next page...

(Table 5.2 Continued...)

n	Description	Output Format	Type
19	millimeters of mercury @ 0°C	MMHG	METRIC
20	centimeters of mercury @ 0°C	CMHG	
21	torr	TORR	
22	kilopascals	KPA	
23	pascals	PA	
24	dynes per square centimeter	DY/CM ²	
25	grams per square centimeter	G/CM ²	
26	kilograms per square centimeter	KG/CM ²	
27	meters of sea water	MSW	
28	ounce per square inch	OSI	
29	pounds per square foot	PSF	
30	tons per square foot	TSF	
31	percent of full scale	%FS	
32	micron of mercury @ 0°C	MHG	
33	tsi	TSI	
34	hPa	HPA	METRIC
* 40	feet of altitude	FEET	ENGLISH
* 41	meters of altitude	METERS	METRIC
** 43	miles per hour	MPH	ENGLISH
** 44	knots	KNOTS	
** 45	meters per second	M/S	METRIC
** 46	kilometers per hour	KM/H	
** 47	mach	MACH	

* Differential or gauge units will not display altitude (units 40 and 41).
 ** The subsonic “calibrated” air speeds and mach numbers are calculated from a differential pressure measurement with the reference pressure at standard sea level (1013.25 mBars). Absolute measuring instruments will not display air speed (units 43 through 47).

Z Command (same as **ZERO** command)
 See Section 6, *Maintenance and Calibration*.

ALTITUDE

*This feature allows the DPG II to measure pressure equivalent to feet or meters of altitude, from -3000 to 100,000 feet. To enable this feature locally see the table of 'Measurement Units' in Section 2, *System Configuration*, and set the switches for feet or meters as shown. When pressure is applied to the instrument, it will display the altitude which is equivalent to that pressure. Altitude pressure units are measured in terms of absolute pressure, only.*

To configure the system for altitude from a remote station, see Table 5.2 for 'Units' in Section 5, *Remote Operation*. Establish communication from the computer to the gauge over the bus.

The syntax for feet is **U40X** and for meters it is **U41X**.

The equivalent altitude will appear on the display. To see the output on the remote system, address the *DPG II* as a talker and read the altitude value.

NOTES:

- 1. The uncertainty of altitude measurement is given in table 7.1 of altitude ranges under Specifications, Section 7. These uncertainties are in addition to the other specified uncertainties.*
- 2. Altitude in this instrument is calculated according to a set of formulas that match the ICAO 1964 standard atmosphere. Table 7.1 in the Specifications section relating to the uncertainty of altitude is based on the published ICAO standard atmosphere tables.*

MAINTENANCE AND CALIBRATION

MAINTENANCE

This instrument was designed for maintenance-free operation. The Main board has a replaceable 0.8 amp fuse and two configuration switches, S3 and S4, which may require access on occasion (see figure 2.1). Otherwise, there are no user serviceable components inside the unit. Mensor Corporation provides complete maintenance and calibration services beyond the warranty period, for a nominal fee. Call 1-512-396-4200 or 1-800-984-4200 (USA only) for details.



CAUTION: ESD PROTECTION REQUIRED. The proper use of grounded work surfaces and personal wrist straps are required when coming into contact with exposed circuits (printed circuit boards) to prevent static discharge damage to sensitive electronic components.

CALIBRATION

The *DPG II* Barometer automatically adjusts the pressure reading for the effects of temperature and non-linearity within the calibrated temperature range of 0–50°C. The process is referred to as dynamic compensation because each reading is adjusted before it is output to the display or to the communication port(s). Thus, a calibrated *DPG II* operated within that temperature band, and with proper zero and span adjustments, will provide accurate barometric measurements.

The *DPG II* should have the zero and span verified periodically to insure the instrument's stability. Initially, the recommended period between calibrations is three months. This period may be extended as confidence is gained in the span stability.

Calibration Environment

For maximum accuracy the Barometer should be operated in an ambient temperature which is stable and within the specified calibration range. In addition the instrument should be at rest on a stable platform which is free of vibration and shock as described in the *Installation* section.

Calibration Standard

The recommended pressure standard is a piston gauge type (deadweight gauge) with an uncertainty of 0.01% of reading or better. A vacuum gauge with an accuracy of 0.5% of reading at 250 to 300 millitorr is recommended for setting zero.

Calibration Medium

The recommended calibration medium is dry nitrogen or clean, dry instrument air.

Calibrating the DPG II Barometer

The procedures for calibrating a *DPG II* from the front panel (LOCAL) are given first, followed by the procedures for calibrating over a bus using a computer (REMOTE). Figure 6.1, which illustrates a calibration setup, shows the additional equipment required for remote calibration as optional.

In the illustration the 'Pressure Standard' is normally a deadweight test instrument, and the 'Volume Controller' refers to a hand operated variable-volume pressure vernier device. A diaphragm type vacuum gauge is recommended over the gauge tube type of vacuum sensor for calibrating sub-atmospheric pressures.

NOTE: *When this instrument was calibrated at the factory the zero and span corrections were stored in memory. If the zero or span values are changed at the front panel, or over the remote bus, the new values immediately displace the factory values in memory. It is recommended that a permanent record be maintained of the 'as received' values, as well as the values that result from each subsequent zero and span update.*

NOTE: *Psi are the recommended units for making zero or span adjustments. Other engineering units might add a small roundoff error.*

CAUTION: THE TUBING, VALVES AND OTHER APPARATUS MUST BE ADEQUATE FOR THE PRESSURE RANGE, OTHERWISE PHYSICAL INJURY TO THE OPERATOR OR BYSTANDERS IS POSSIBLE.

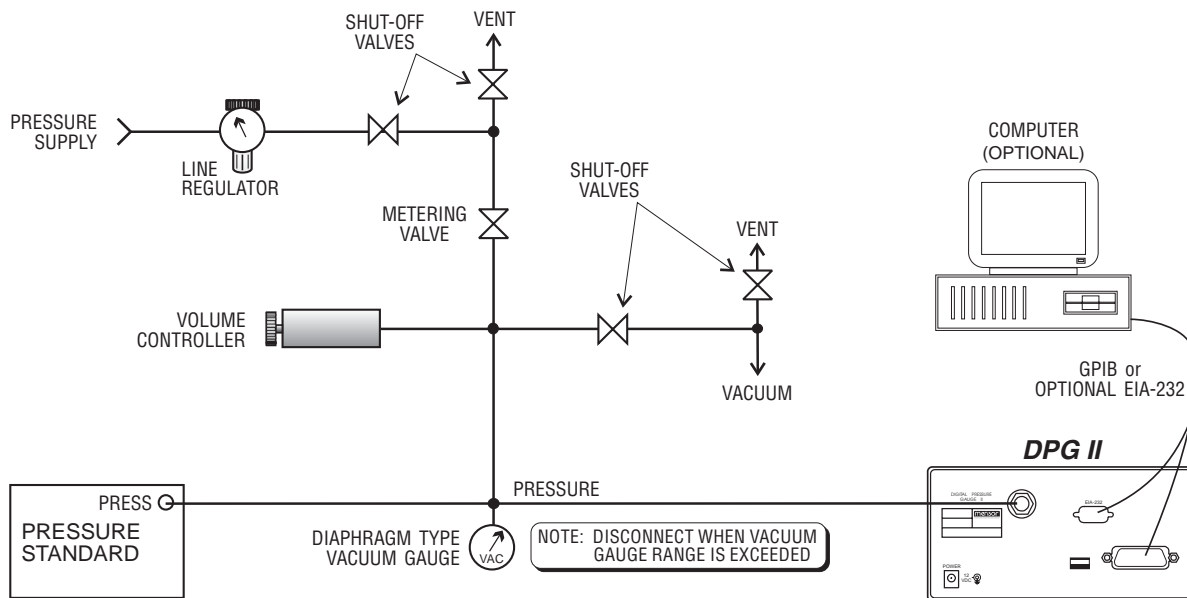

Figure 6.1 - Calibration Setup

Local Zero Adjustment

Connect a vacuum pump of at least 21 liters per minute capacity to the rear panel. Evacuate to a low pressure that will still maintain a viscous flow, typically 500 millitorr. At lower pressures, with viscous flow interrupted, the vacuum readings are less reliable and the actual pressure at any particular point in the system is then questionable.

When the target vacuum has stabilized convert the millitorr reading to an equivalent instrument reading for the active measurement units. Millitorr conversion factors are provided in table 9.2 in the Appendix.

Set the rear panel switches S2-1 through S2-3 in the down position (ZERO, NORMAL, NORMAL). In this condition the front panel switches are enabled for zero adjustment. Press either – or + to display the current zero offset in the active measurement units. Hold either of the two switches down for more than one second to cause the offset to begin incrementing or decrementing the least significant digit. The longer a switch is held the faster the digits will change up to the maximum zero adjustment range of approximately ± 16 psi.

Local Span Adjustment

To enable the front panel – and + switches to affect the span adjustment set internal switch S3-8 to OFF (see Figure 2.1), and rear panel switch S2-1 to SPAN (up), and S2-2 and S2-3 to NORMAL (down). Then press either the – or the + switch to cause the instrument display to show the current offset from full span in the active measurement units. To change the span offset hold either the – or the + switch to increment or decrement the offset value as desired, up to a maximum of $\pm 0.1\%$ of instrument span (± 0.017 psi). To remove the offset, press both the – and the + switches and release them simultaneously.

Remote Zero Adjustment

Refer to figure 6.1 for the recommended setup. Connect a vacuum pump to the pressure port. Evacuate the sensor to approximately 500 millitorr.

Convert the vacuum reading to an equivalent instrument reading for the active measurement units. Millitorr conversion factors are provided in Table 9.2 in the Appendix.

Send **Z0X** to clear the stored zero correction from RAM.

Record the *DPG II* output. Next subtract the vacuum reading (in equivalent units) from the instrument reading. This difference will be the zero offset.

The sign of the zero correction value will be opposite to that of the zero offset. Send the zero correction using the **Z(value)X** command. The maximum number of characters allowed in the correction value is seven (7), including the decimal point and the minus sign, if needed.

Example: For a 0-15 psia unit with a 500 millitorr vacuum applied, using psi units:

DPG II output = -0.0029 psia
500 millitorr = 0.0097 psi absolute pressure
-0.0029 (-) 0.0097 = -0.0126 psi offset
Correction value = +0.0126

Send **Z.0126**

The *DPG II* should now display .0097 psia.

Remote Span Adjustment

The syntax for span adjustment is **SnX** where **n** is a numeric value to be sent over the bus.

Send **S0X** to clear the stored correction.

Apply a known pressure equal to the span of the instrument.

Get the reading from the *DPG II*.

Subtract the applied pressure from the *DPG II* reading. The result is the span offset. Invert the sign of the span offset to obtain the correction value.

Send the correction using the **S(value)X** command. The maximum number of characters allowed in the correction value is seven (7), including the decimal point, and, if applicable, a minus sign.

<p>NOTE: <i>Span adjustment can be accomplished using the newer 'Span s' command as shown under 'Remote Operation', Section 5.</i></p>

Correction Value Query

The stored corrections for zero and span can be retrieved over the communication ports using the **Q7X** command. See 'Device Dependent Messages' in the *Remote Operation* section of this manual for specific details. This command may be useful in determining the actual changes in zero and span. Unauthorized alterations of the values can be detected by comparison with recorded values for the corrections.

SPECIFICATIONS

These specifications apply to a Mensor Precision Barometer consisting of a *DPG II* incorporating a specially calibrated Silicon Pressure Transducer (SPT). This instrument is available with various accuracy and temperature range configurations as shown in table 7.1 below. These specifications are subject to change without notice.

RANGES

(Before Zero adjustment, Span adjustment, or Sea Level Correction)

Displayed Range: -1.66 to 21.58 psia (-3.39 to 43.94 inHgA)

Calibrated Range: 0 to 17 psia (0 to 34.6 inHgA)

PRESSURE MEDIUM

Clean, dry, non-corrosive gases unless otherwise specified on the factory calibration reports. The *DPG II* is not intended for use with oxygen as the pressure medium.

UNCERTAINTY

Transducer

Over the full calibrated range of 0 to 17 psia (0 to 34.6 inHgA), and within the compensated temperature range, the measurement error due to the combined effects of hysteresis, repeatability, linearity and temperature is 0.01% of full scale except as noted for Model 14500C as shown in table 7.1.

Table 7.1 – Accuracy/Temperature Configurations

MODEL	ACCURACY	TEMP RANGE
14500A	0.010% R	0 to 50°C
14500B	0.010% R	15 to 45°C
14500C	0.025% R	15 to 45°C

Between 10.8 and 16.7 psia (22.0 to 34.0 inHgA @ 0°C) the combined uncertainty is 0.01% of reading for types A and B, and 0.025% of reading for type C.

Digital Output

The *DPG II* has an additional uncertainty of one half the value of the least significant digit of the output (display, bus or optional BCD).

Analog Output

The uncertainty of the analog output option (0–10 vdc) is 0.05% of full scale. This uncertainty is in addition to the stated uncertainty of the transducer.

Calibration Standard

0.01% of reading or 0.0001 psi, whichever is greater.

Measurement Error Due To Temperature Change

Less than 0.001% of full scale per degree Celsius of temperature change within the compensated temperature range under controlled (test chamber) conditions. However, the observed effect may appear somewhat greater in environments with commonly encountered temperature variations.

Altitude Pressure Units and Local Elevation Correction

Altitude pressure units (feet, meters) and local elevation corrections have an additional uncertainty of the following:

Table 7.2 – Additional Uncertainty of Altitude/Feet

Altitude, Feet:	Additional Uncertainty
-3000 to 5000	3 feet
5001 to 30000	4 feet

HOURLY BAROMETRIC CHANGE

The readings used to calculate hourly change are taken at one-minute intervals with a timing uncertainty of +0.05 second per minute. The cumulative timing error is no greater than +0.25 seconds per hour.

COMPENSATED TEMPERATURE RANGE

0 to 50°C (type A) or 15 to 45°C (type B or C) as shown in table 7.1. Special calibrations for other temperature ranges are available. Contact Mensor for details.

OUTPUT RESOLUTION

Up to 2 parts per million depending on the range of the currently selected units. In STANDARD mode the full scale resolution will be between 5,000 and 50,000. In HIGH mode the same units will have a full scale resolution between 50,000 and 500,000.

Optional Outputs

0–5 vdc or 0–10 vdc analog into a 2K ohm (max.) load, provides 1 part in 4096 resolution.
24 lines BCD data and 8 status lines (LSTTL compatible) capable of 0–999,999.

RESPONSE TIME

Less than 0.2 seconds for 100% of full scale pressure step input (update rate is approximately 120 per second).

WARM-UP

Approximately 15 minutes.
Zero Drift: (after warm-up)
0.01% full scale 30 days
Zero may be reset without affecting span or linearity.

Span Drift: (full scale reading minus zero reading, after warm-up)
0.01% full scale 90 days
Span may be reset without affecting zero or linearity.

OVER PRESSURE RATING

45 psia maximum.

ATTITUDE ERROR

Negligible in any attitude (orientation).

OPERATING ENVIRONMENT

Temperature: 0°C to 50°C. Note: This is not the compensated temperature range.
Humidity: 5% to 95% RH non-condensing humidity.

SHIPPING, STORAGE AND HANDLING ENVIRONMENT

-20 to 70°C.
Minimal vibration.
5 gravities acceleration maximum.
Non-condensing humidity.

OUTPUTS

Front Panel Display
IEEE 488.1-1978 Interface Bus (GPIB)

Optional: EIA-232 Serial Port
0-10 vdc analog
Binary Coded Decimal (BCD)

DISPLAY

Two lines of 16 each 0.2 inch high characters.
Vacuum fluorescent, blue filter.

POWER

Requires 10 to 15 vdc @ 600 mA.

FUSE

0.8 amp (See figure 2.1).

MOUNTING

Table model is standard. A rack adapter and carrying handle are available.

PRESSURE CONNECTION

The pressure port on the transducer is a female 7/16-20 SAE/MS straight thread per MS16142 and SAE J514 table 14. It requires a tube fitting boss seal with an o-ring per MS33656. Mensor provides a 1/8 NPT adapter and a 1/8 NPT filter with the SPT. Connections can be made to the adapter or directly to the transducer port with the proper fitting.

SIZE

7.56" wide x 3.78" high x 9.50" deep (19.20 cm x 9.60 cm x 24.38 cm).
7.56" wide x 6.00" high x 9.50" deep (19.20 cm x 15.24 cm x 24.38 cm) with optional battery pack.

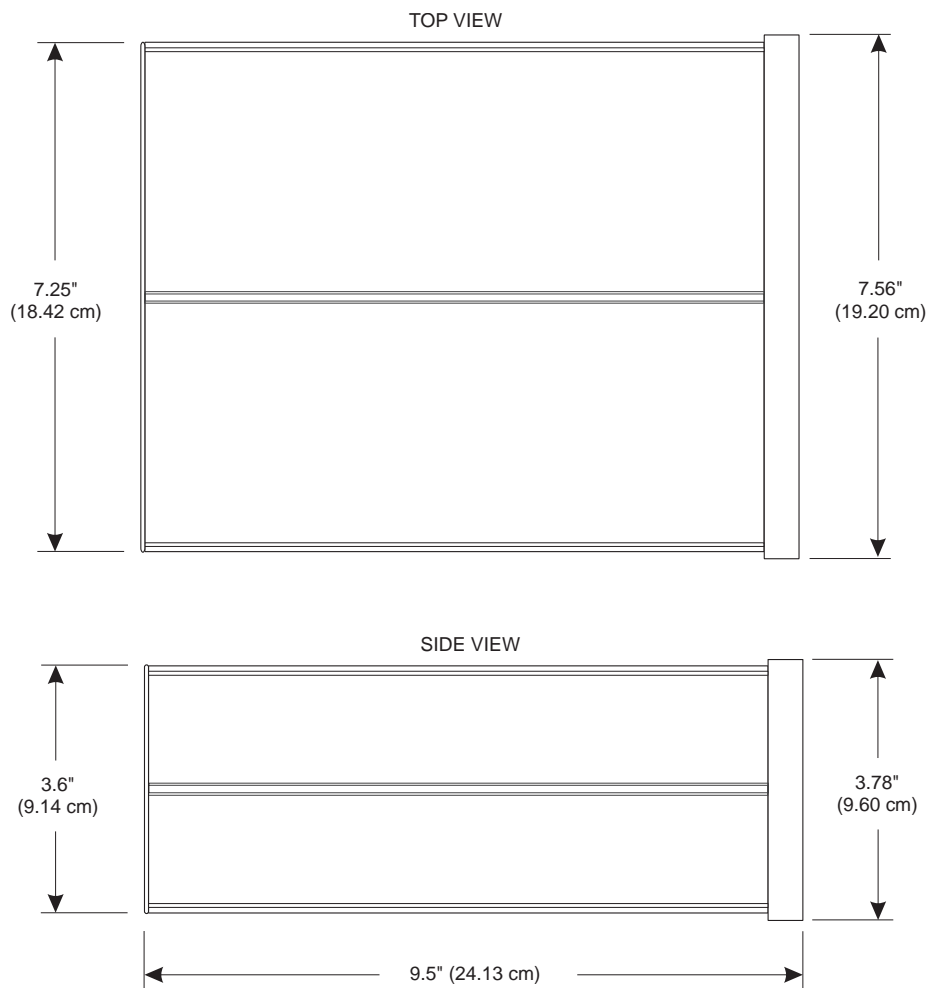

FIGURE 7.1 - DIMENSIONAL OUTLINE

WEIGHT

4.7 pounds (2.13 kg).

9.0 pounds (4.08 kg) with optional battery pack.

TRANSDUCER VOLUME (CUBIC CENTIMETERS)

Pressure Chamber: 0.6 cc

OPTIONS

	Part Number	Page
POWER		
Plug-in module	0014035001	
100 to 125 volts, 50/60 Hz		
9 to 12 vdc @ 750 mA.		
Plug-in module	0014035002	
200 to 250 volts, 50/60 Hz		
12 to 14 vdc @ 750 mA.		
Battery Pack-Portable	0014080001	8-2
12 vdc @ 4 amp Hour		
Battery Pack Kit	0014080002	8-2
Battery Charger	0014095001	8-3
Power Cord, 12 vdc/Automotive	0014089001	8-3
RACK MOUNT KIT		
One DPG	0011455001	8-3
Two DPG's	0011455002	
Panel Mount Hardware	0011455003	
HANDLE KIT	0014034001	8-4
CARRYING CASE	several available	8-5
EIA-232 INTERFACE	0014014001	8-6
ANALOG OUTPUT	0014014001	8-9
BCD OUTPUT	0012976002	8-10

RECHARGEABLE BATTERY PACK (001408000X)

The battery pack is a self-contained, rechargeable power source that attaches to and operates the *DPG II*. A new, fully charged battery pack provides up to 10 hours of continuous operation for the instrument, and will decrease as the batteries age.

The battery pack is installed by sliding it's top bar into the T-slot extruded into the bottom side of the *DPG II*. The two thumb-screws on the underside are then tightened to apply clamping pressure against the bottom of the *DPG II*.

The power connector cable is then plugged into the POWER socket of the *DPG II*. An LED on the front of the battery pack will come on when the capacity of the batteries has been reduced to approximately 15 to 20 minutes of *DPG II* operating time.

The Rechargeable Battery Pack is available in two configurations, as follows:

- 0014080001 Battery Pack, Only
- 0014080002 Battery Pack, Battery Charger and Handle Kit

If the *DPG II* was ordered as a battery powered instrument it was delivered with the battery pack and handle kit installed, and included a separate battery charger. The 0014080001 battery pack can then be ordered as a spare or backup power supply without purchasing an extra charger or handle.

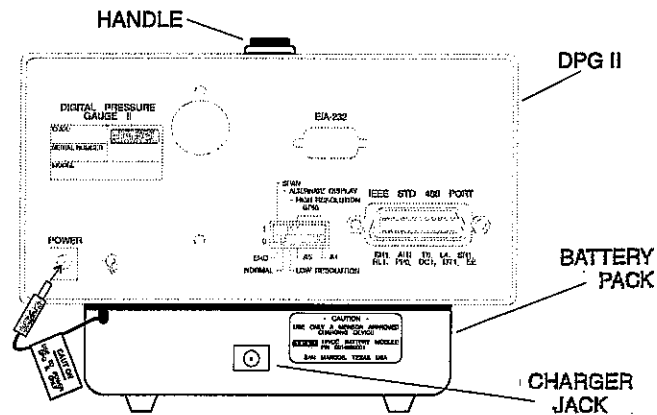

Figure 8.1 - Battery Pack

BATTERY CHARGER (0014095001)

To recharge the battery pack plug a battery charger into the socket provided in the center on the rear of the battery pack case. Total charging time for a fully discharged battery pack is 10 hours with the *DPG II* turned off.

NOTES:

1. The voltage select switch located on the bottom of the charger must be set for the local line voltage (115 or 220 VAC) before plugging it into a power source.
2. While it is possible to operate a *DPG II* from the battery charger while it is charging, the charging time will be greatly extended.

AUTOMOTIVE POWER CORD (0014089001)

The automotive power cord patches between a 12 volt automobile cigarette lighter, and the power connector on the rear of the *DPG II*. The cord includes current limiting circuitry to protect both the instrument and the car battery. Use only a Mensor supplied automotive power cord for this purpose.

RACK MOUNT KIT (001145500X)

The rack panel is available with either one or two cut-outs for mounting *DPG II*s. The panel fits a 5-1/4 inch opening in a standard 19 inch rack. To mount an instrument into the panel simply insert it into a panel cutout from the front until the *DPG II* front bezel stops it. Then, from the rear of the instrument slide the two clamp bars into the extruded slots on either side of the instrument case until the bars rest against the inside of the rack panel. Finally, run the #6-32 Allen set screws against the tail end of each of the clamp bars to apply clamping pressure against the rack panel.

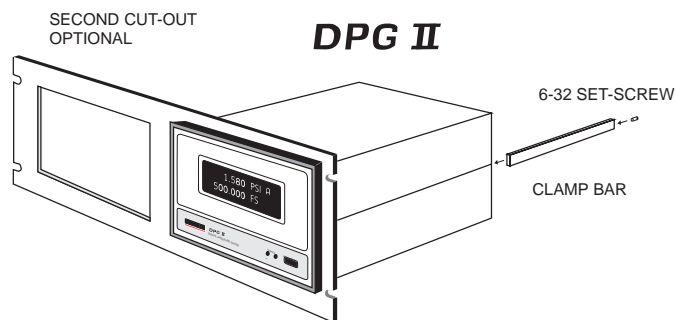

Figure 8.2 - Rack Mount Diagram

HANDLES

Two different handles are available for the *DPG II* as shown in figure 8.3. If either handle is ordered at the time an instrument is ordered it will be mounted by Mensor prior to shipment. However, both handles are available in kit form and can be ordered separately. Each handle kit will include all of the necessary hardware and mounting instructions.

Carrying Handle (0014034001)

The 0014034001 Carrying Handle is a collapsible, stitched-leather handle with chrome fittings. This handle is easily attached and removed, and is suitable for carrying any *DPG II*. While it is customary to mount this handle on the top, it can be mounted to either side that is not otherwise occupied.

Tilt-Stand/Carrying Handle (0014068001)

The 0014068001 Tilt-Stand/Handle is a foldable, vinyl coated, formed steel rod with mounting brackets. When folded down it acts as a tilt stand as seen in figure 8.3, or it can be folded forward to use as a carrying handle. This device is not suitable for use with a battery powered *DPG II*.

NOTE: The screws that secure the two side brackets for the tilt stand are self-tapping screws that thread themselves into the case channels. If the brackets are removed or relocated the removed screws will leave bright metallic screw tracks in the black channels.

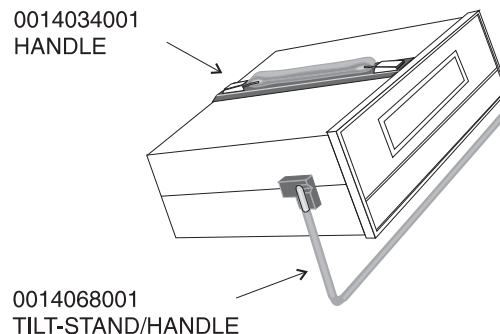

Figure 8.3 - Handles

CARRYING CASES (0014259001, 0014261001 AND 14289001)

Mensor offers a vanity case style and two briefcase styles of carrying cases for the *DPG II*. Each case is constructed of a high impact plastic exterior, an interlocking tongue and groove opening, a vinyl handle, and nickle-chrome fixtures. Each case has an interior filled with high density polyurethane foam with a die-cut cavity to cushion the instrument. There are additional cavities to store related accessories, and the manual. Contact Mensor for the particular carrying case to best suit your application.

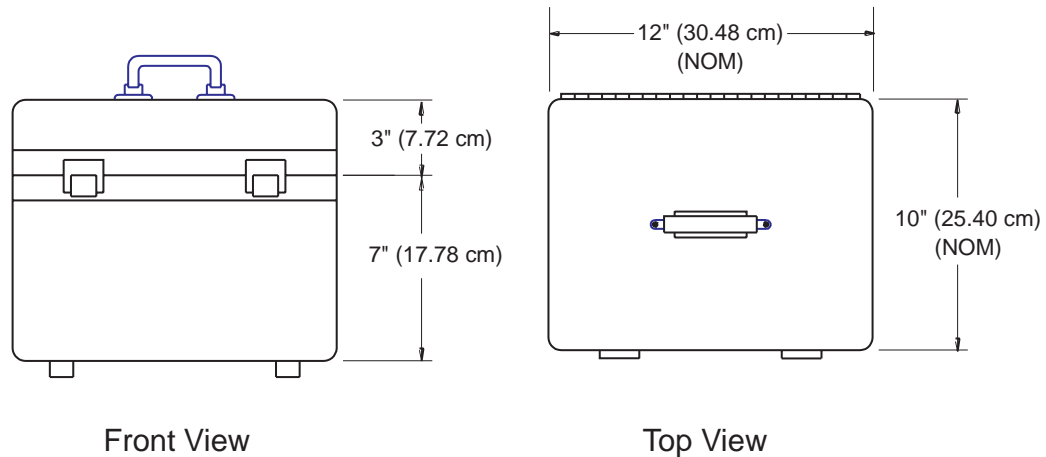

Figure 8.4 - CARRYING CASE (0014261001 shown)
(brief case style also available)

EIA-232 SERIAL COMMUNICATION PORT (0014014001)

This option requires a communication board (see figure 8.5) and a male DB-9 serial port connector on the rear panel. The signal levels comply with those defined in ANSI/EIA 232-D-1986 standard, "Interface Between Data Terminal Equipment (DTE) and Data Circuit-Terminating Equipment (DCE) Employing Serial Binary Data Interchange", commonly known as the EIA-232 interface bus. The standard is available from: Electronic Industries Association, Engineering Dept., 2001 Eye Street N.W., Washington, D.C. 20006.

With this option and the appropriate cable a *DPG II* can communicate with either DTE or DCE devices over the bus. To request data output over the serial port the operator must end the command with a ?. Upon receipt of the ? the *DPG II* will output its current data to the serial bus.

All device dependent commands described in the *Remote Operation* section are also valid over the EIA-232 bus. Every command sent must be read back to avoid a buffer overflow.

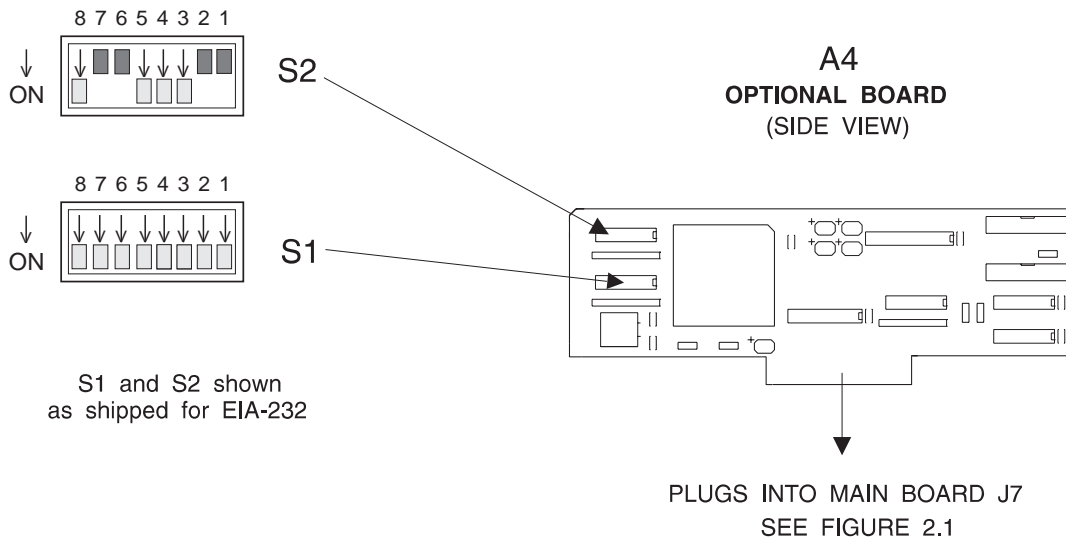

Figure 8.5 - Communication Board

EIA-232 Switch Settings (Communications Board)

Switches S1-1 through S1-8 on the Communications Board (see figure 8.5) must all be ON to enable EIA-232. Switches S2-1 through S2-8 (figure 8.5) will set the EIA-232 functions as follows:

Table 8.1 – EIA-232 Switch Functions and Settings

S2–	Function	Switch ON	Switch OFF
S2-1	Parity	Off	On
S2-2	Parity	Odd	Even
S2-3	Stop Bits	One	Two
S2-4	Data Bits	Seven	Eight
S2-5	Baud Rate	(See Baud Rate Table 8.2, below)	
S2-6			
S2-7			
S2-8	EIA-232	Enabled	Disabled

BAUD RATE: S2-5 through S2-7 per the following Table 8.2.

Table 8.2 – Baud Rate (/ indicates OFF)

Baud Rate	S2-5	S2-6	S2-7
150	ON	ON	ON
300	/	ON	ON
600	ON	/	ON
1200	/	/	ON
2400	ON	ON	/
4800	/	ON	/
9600	ON	/	/
19,200	/	/	/

The cable configuration to connect the *DPG II* to the external equipment, will depend on the type of equipment (DTE or DCE), the equipment connector (9-pin or 25-pin), and the connector gender (male or female). In many cases a pre-assembled, purchased cable can be used (with or without a gender changer), or the user may choose to assemble the cable. The *DPG II* to DTE cable connections are illustrated in figure 9.2 in the *Appendix*. The pin functions for the EIA-232 connector on a *DPG II* are described below.

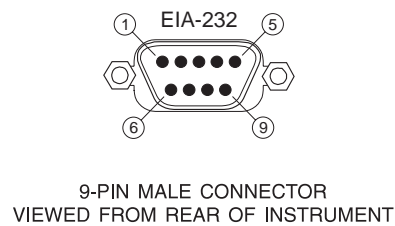

PIN#	DESCRIPTION
1	CD - Carrier Detect (input)
2	RD - Receive Data (input)
3	TD - Transmit Data (output)
4	DTR - Data Terminal Ready (output)
5	GND - Ground
6	DSR - Data Set Ready (input)
7	RTS - Ready to Send (output)
8	CTS - Clear to Send (input)
9	RI - Ring Indicator (not used)

Data Format: Serial, binary asynchronous, 7 or 8 data bits.
1 or 2 stop bits, odd, even, or no parity.

Baud Rates: 150, 300, 600, 1200, 2400, 4800 or 9600 baud.

Buffer Size: One character.

Connector: 9 pin male (DB-9).

Handshaking: Provided by the RTS and DTR lines.
The timing is shown in the following diagram:

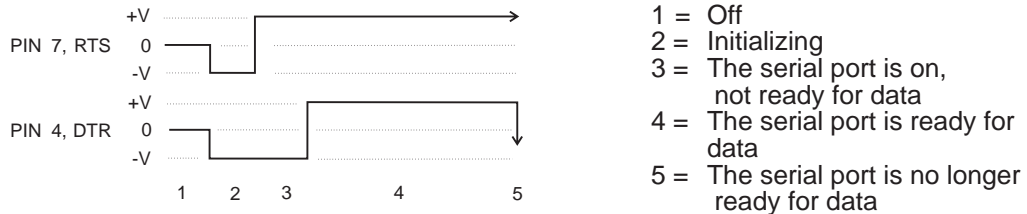

ANALOG AND BCD OUTPUT (001297600X)

This option requires an optional DAC/BCD printed circuit board (figure 8.7) installed in J7 of the Main Board (refer to figure 2.1). Also required is a special rear panel which includes a standard 37 pin D-sub connector labeled ANALOG/BCD OUTPUT. The connector pin configuration is illustrated in figure 8.6, and the pin assignments are listed in Table 8.3. Analog output and BCD output are independent functions as described below and on the following page. Specifications for each function are included in the *Specifications* section.

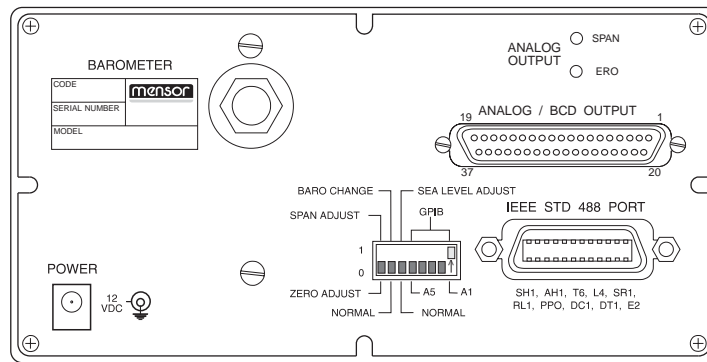

Figure 8.6 - Rear Panel (Analog & BCD Output)

Analog Output (0012976001)

The analog output can be ordered as either 0-5 or 0-10 volt full scale output. This is a dc signal that is proportional to the full scale pressure range. This signal is derived by processing the temperature and pressure signals from the transducer into a digital format, compensated pressure value. It is this digital pressure value that is output to the front panel display, to the BCD data lines, and made available to the GPIB bus. This compensated pressure value is also fed to a digital-to-analog converter (DAC) that has a 5 or 10 volt full scale output. There is a zero and a span pot accessible through the rear panel to adjust the analog signal. Using these two pots the operator can bring the analog signal into agreement with the front panel pressure reading during a given process run. The correct value for zero pressure is 0.000 volts out, and for any positive pressure the correct voltage is derived from the formula $(P/FS) \times \text{full scale voltage}$ where P is the front panel pressure reading, FS is the full scale range of the *DPG II*. The numbers plugged into the formula and the output voltage value should be carried out to the full

resolution of the *DPG II* for best results. The resulting output may deviate as much as 0.005 volts from the calculated value due to the resolution limits of the DAC. Use caution when operating near zero or full scale voltage output. There is no overrange capability nor any error indication if these limits are exceeded.

BCD Output (0012976002)

The BCD output consists of 24 lines of BCD numbers (six decimal digits), three lines to define the decimal point placement or an overrange condition, three lines to identify the engineering units, two ground lines, one polarity indicator, and one BCD Ready indicator. The BCD signals reflect the same pressure reading as the front panel display, and are updated at the same rate. However, the BCD signals are not updated during the time that a GPIB operation is being processed. See Table 8.3 for the Analog/BCD Output connector pin assignments.

Table 8.3 – Analog/BCD Output Pin Assignments

Pin	Function
1	Analog -
20	Analog + (5 or 10 volt potential; DO NOT connect to BCD decoder)
2	GND
21	GND
3	BCD unit code c
22	BCD unit code b
4	BCD unit code a
23	BCD decimal code c
5	BCD decimal code b
24	BCD decimal code a
6	BCD Busy (low indicates ready)
25	BCD Positive (low indicates negative number)
7	BCD 1
26	BCD 2
8	BCD 4
27	BCD 8
9	BCD 10
28	BCD 20

Continued on next page...

Pin Assignments Continued...

Pin	Function
10	BCD 40
29	BCD 80
11	BCD 100
30	BCD 200
12	BCD 400
31	BCD 800
13	BCD 1k
32	BCD 2k
14	BCD 4k
33	BCD 8k
15	BCD 10k
34	BCD 20k
16	BCD 40k
35	BCD 80k
17	BCD 100k
36	BCD 200k
18	BCD 400k
37	BCD 800k
19	no connection

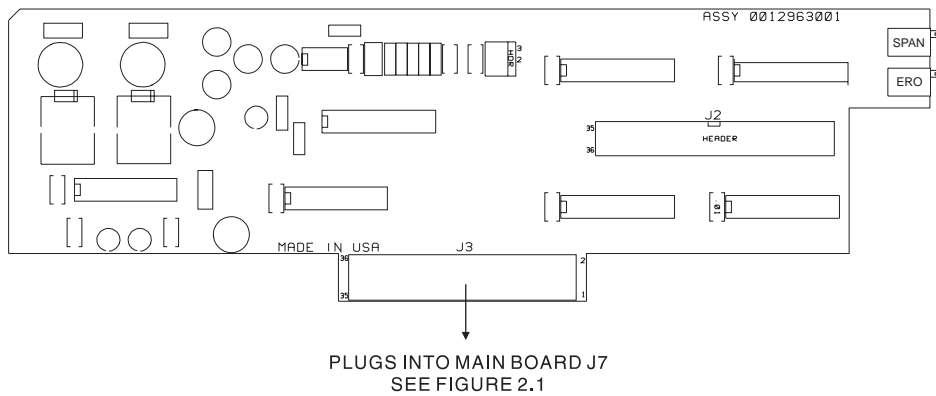

Figure 8.7 - Analog/BCD Output Board

Table 8.4 – Units Codes

abc	Units 'As Shipped'	Optional Units
000	psi	Base unit – always available
001	inH2O @ 4C	Or as configured by S4-2 through S4-8
010	inHg @ 0C	Will be the same units, and in the same order as those available to the front panel UNITS switch. See 'Measurement Units' in the <i>System Configuration</i> section.
011	hPa	
100	mBar	
101	Torr	
110	mmHg @ 0C	
111	kPa	

Table 8.5 – Decimal Codes

abc	Decimal Location
000	XXXXXX (no decimal)
001	XXXXX.X
010	XXXX.XX
011	XXX.XXX
100	XX.XXXX
101	X.XXXXX
110	.XXXXX
111	OVERRANGE OR ERROR

NOTES:

1. The two analog lines (pins 1 and 20) are 0 to 10v maximum, while all BCD data and status lines are LSTTL compatible.
2. Measurement units programmed remotely by GPIB which are not available to BCD will cause an overrange or error signal on the Decimal Codes lines (pins 5, 23 and 24 = high). The error condition will remain on those lines until GPIB reformats to units which are recognizable by BCD, or until the DPG II is powered down and reinitialized.

APPENDIX

TABLE OF CONTENTS

Table 9.1 – Conversion Factors, psi	9-2
Table 9.2 – Conversion Factors, millitorr	9-4
Table 9.3 – Temperature Conversion	9-6
Table 9.4 – Materials in Contact with Pressure Medium	9-7
Head Pressure Correction	9-8
Table 9.5 – Gas Density	9-8
Head Pressure Calculation	9-9
Figure 9.1 – Head Pressure Calculation	9-9
Table 9.6 – Standard Sea Level Pressure at Various Elevations	9-10
Table 9.7 – Pressure Offsets at Various Elevations	9-11
Table 9.8 – Chassis Dip Switches	9-12
Figure 9.2 – EIA-232 Cable Connector	9-13
Table 9.9 – Quick Reference List of Commands	9-14
Sample IEEE Program	9-16

CONVERSION FACTORS, PSI

The following table lists conversion factors which should be used as multipliers of the pressure to be converted to or from psi.

Table 9.1 – Conversion Factors, psi

Code	Pressure Unit	To convert from psi	To convert to psi
1	psi	1.0	1.0
2	inHg @ 0°C	2.03603	0.491153
3	inHg @ 60°F	2.04177	0.489771
4	inH ₂ O @ 4°C	27.6807	0.0361263
5	inH ₂ O @ 20°C	27.7297	0.0360624
6	inH ₂ O @ 60°F	27.708	0.03609
7	ftH ₂ O @ 4°C	2.30672	0.433515
8	ftH ₂ O @ 20°C	2.310808	0.432749
9	ftH ₂ O @ 60°F	2.3090	0.43309
10	mtorr	51715.1	0.0000193367
11	in seawater	26.9664	0.037083
12	ft seawater	2.2472	0.44500
13	atm	0.06804596	14.69595
14	bars	0.06894757	14.50377
15	mbar	68.94757	0.01450377
16	mmH ₂ O @ 4°C	703.089	0.00142230
17	cmH ₂ O @ 4°C	70.3089	0.0142230
18	mH ₂ O @ 4°C	0.703089	1.42230
19	mmHg @ 0°C	51.7151	0.0193367
20	cmHg @ 0°C	5.17151	0.193367
21	torr	51.7151	0.0193367
22	kPa	6.894757	0.1450377

Continued on next page...

Table 9.1 continued...

Code	Pressure Unit	To convert from psi	To convert to psi
23	Pa	6894.757	0.0001450377
24	dynes/cm ²	68947.57	0.00001450377
25	g/cm ²	70.30695	0.01422334
26	kg/cm ²	0.07030695	14.22334
27	m seawater	0.684947	1.4600
28	oz/in ²	16.0	0.06250000
29	psf	144.0	0.006944445
30	tsf	0.072	13.88889
31	% FS	(psi/range) X 100	(% FS X range) / 100
32	micron Hg @ 0°C	51715.0733	0.0000193367
33	tsi	0.0005	2000.0
34	hPa	68.94757	0.01450377

CONVERSION FACTORS, MILLITORR

The following table lists conversion factors which should be used as multipliers of the pressure to be converted to or from millitorr.

Table 9.2 – Conversion Factors, millitorr

Code	Pressure Unit	To convert from millitorr	To convert to millitorr
1	psi	0.0000193367	51715.1
2	inHg @ 0°C	0.0000393701	25400.0
3	inHg @ 60°F	0.0000394812	25328.5
4	inH ₂ O @ 4°C	0.000535253	1868.27
5	inH ₂ O @ 20°C	0.000536201	1864.97
6	inH ₂ O @ 60°F	0.000535774	1866.5
7	ftH ₂ O @ 4°C	0.0000446045	22419.3
8	ftH ₂ O @ 20°C	0.0000446834	22379.6
9	ftH ₂ O @ 60°F	0.0000446478	22398
10	mtorr	1.0	1.0
11	in seawater	0.000521442	1918
12	ft seawater	0.0000434535	23010
13	atm	0.00000131579	760002
14	bars	0.00000133322	750064
15	mbar	0.00133322	750.064
16	mmH ₂ O @ 4°C	0.0135954	73.5541
17	cmH ₂ O @ 4°C	0.00135954	735.541
18	mH ₂ O @ 4°C	0.0000135954	73554.1
19	mmHg @ 0°C	0.001	1000.00
20	cmHg @ 0°C	0.0001	10000.0
21	torr	0.001	1000.00
22	kPa	0.000133322	7500.64

Continued on next page...

Table 9.2 continued...

Code	Pressure Unit	To convert from millitorr	To convert to millitorr
23	Pa	0.133322	7.50064
24	dynes/cm ²	1.33322	0.750064
25	g/cm ²	0.00135951	735.561
26	kg/cm ²	0.00000135951	735561
27	m seawater	0.0000132446	75500
28	oz/in ²	0.000309388	3232.19
29	psf	0.00278449	359.132
30	tsf	0.00000139224	718265
31	% FS	(mtorr/range) x 100	(% FS x range) / 100
32	micron Hg @ 0°C	1.0	1.0
33	tsi	0.00000000967	103430147.
34	hPa	0.00133322	750.064

TEMPERATURE CONVERSION (Table 9.3)

Find the known value in a center (shaded) column. If the known value is in °C then the equivalent value is found in the °F column, or if the known value is in °F then the conversion is found in the °C column.

°C		°F	°C		°F	°C		°F	°C		°F
-17.78	0	32.00	10.00	50	122.00	37.78	100	212.00	65.56	150	302.00
-17.22	1	33.80	10.56	51	123.80	38.33	101	213.80	66.11	151	303.80
-16.67	2	35.60	11.11	52	125.60	38.89	102	215.60	66.67	152	305.60
-16.11	3	37.40	11.67	53	127.40	39.44	103	217.40	67.22	153	307.40
-15.56	4	39.20	12.22	54	129.20	40.00	104	219.20	67.78	154	309.20
-15.00	5	41.00	12.78	55	131.00	40.56	105	221.00	68.33	155	311.00
-14.44	6	42.80	13.33	56	132.80	41.11	106	222.80	68.89	156	312.80
-13.89	7	44.60	13.89	57	134.60	41.67	107	224.60	69.44	157	314.60
-13.33	8	46.40	14.44	58	136.40	42.22	108	226.40	70.00	158	316.40
-12.78	9	48.20	15.00	59	138.20	42.78	109	228.20	70.56	159	318.20
-12.22	10	50.00	15.56	60	140.00	43.33	110	230.00	71.11	160	320.00
-11.67	11	51.80	16.11	61	141.80	43.89	111	231.80	71.67	161	321.80
-11.11	12	53.60	16.67	62	143.60	44.44	112	233.60	72.22	162	323.60
-10.56	13	55.40	17.22	63	145.40	45.00	113	235.40	72.78	163	325.40
-10.00	14	57.20	17.78	64	147.20	45.56	114	237.20	73.33	164	327.20
-9.44	15	59.00	18.33	65	149.00	46.11	115	239.00	73.89	165	329.00
-8.89	16	60.80	18.89	66	150.80	46.67	116	240.80	74.44	166	330.80
-8.33	17	62.60	19.44	67	152.60	47.22	117	242.60	75.00	167	332.60
-7.78	18	64.40	20.00	68	154.40	47.78	118	244.40	75.56	168	334.40
-7.22	19	66.20	20.56	69	156.20	48.33	119	246.20	76.11	169	336.20
-6.67	20	68.00	21.11	70	158.00	48.89	120	248.00	76.67	170	338.00
-6.11	21	69.80	21.67	71	159.80	49.44	121	249.80	77.22	171	339.80
-5.56	22	71.60	22.22	72	161.60	50.00	122	251.60	77.78	172	341.60
-5.00	23	73.40	22.78	73	163.40	50.56	123	253.40	78.33	173	343.40
-4.44	24	75.20	23.33	74	165.20	51.11	124	255.20	78.89	174	345.20
-3.89	25	77.00	23.89	75	167.00	51.67	125	257.00	79.44	175	347.00
-3.33	26	78.80	24.44	76	168.80	52.22	126	258.80	80.00	176	348.80
-2.78	27	80.60	25.00	77	170.60	52.78	127	260.60	80.56	177	350.60
-2.22	28	82.40	25.56	78	172.40	53.33	128	262.40	81.11	178	352.40
-1.67	29	84.20	26.11	79	174.20	53.89	129	264.20	81.67	179	354.20
-1.11	30	86.00	26.67	80	176.00	54.44	130	266.00	82.22	180	356.00
-0.56	31	87.80	27.22	81	177.80	55.00	131	267.80	82.78	181	357.80
0.00	32	89.60	27.78	82	179.60	55.56	132	269.60	83.33	182	359.60
0.56	33	91.40	28.33	83	181.40	56.11	133	271.40	83.89	183	361.40
1.11	34	93.20	28.89	84	183.20	56.67	134	273.20	84.44	184	363.20
1.67	35	95.00	29.44	85	185.00	57.22	135	275.00	85.00	185	365.00
2.22	36	96.80	30.00	86	186.80	57.78	136	276.80	85.56	186	366.80
2.78	37	98.60	30.56	87	188.60	58.33	137	278.60	86.11	187	368.60
3.33	38	100.40	31.11	88	190.40	58.89	138	280.40	86.67	188	370.40
3.89	39	102.20	31.67	89	192.20	59.44	139	282.20	87.22	189	372.20
4.44	40	104.00	32.22	90	194.00	60.00	140	284.00	87.78	190	374.00
5.00	41	105.80	32.78	91	195.80	60.56	141	285.80	88.33	191	375.80
5.56	42	107.60	33.33	92	197.60	61.11	142	287.60	88.89	192	377.60
6.11	43	109.40	33.89	93	199.40	61.67	143	289.40	89.44	193	379.40
6.67	44	111.20	34.44	94	201.20	62.22	144	291.20	90.00	194	381.20
7.22	45	113.00	35.00	95	203.00	62.78	145	293.00	90.56	195	383.00
7.78	46	114.80	35.56	96	204.80	63.33	146	294.80	91.11	196	384.80
8.33	47	116.60	36.11	97	206.60	63.89	147	296.60	91.67	197	386.60
8.89	48	118.40	36.67	98	208.40	64.44	148	298.40	92.22	198	388.40
9.44	49	120.20	37.22	99	210.20	65.00	149	300.20	92.78	199	390.20

MATERIALS IN CONTACT WITH PRESSURE MEDIUM

The recommended pressure medium is clean, dry, non-corrosive gases. Consult Mensor Corporation for applications requiring liquid-filled pressure sensors.

Table 9.4 – Materials In Contact With Pressure Medium

Materials in contact with Pressure Medium	
<i>Metallics</i>	Non-Metallics
Aluminum	Buna-N Rubber
Brass	Silicon
	Silicone Grease
	Epoxy
	Polyester

HEAD PRESSURE CORRECTION

The accuracy of pressure measurement depends on several factors, one of which is the consideration of the head pressure in the system. The pressure medium, whether a gas or liquid, can cause an error in the measurement if not considered. In some cases the offset may be insignificant, and it may be ignored. The following information provides instructions for determining the density of the pressure medium and how to calculate the head pressure effect.

Gas Density

Liquids and gases have mass and are affected by gravity. The extent of the effect is dependent upon the density of the pressure medium. Liquids normally have a constant density that does not change with pressure. Gases however, increase in density as the pressure increases. To determine the density of a gas at a specific pressure multiply the absolute pressure by the density from the following table. For gas the head pressure difference due to temperature changes within the compensated temperature range will be insignificant.

Table 9.5 – Gas Density

Gas @ 23°C		Density per psi in pounds/in ³ (<i>D_{psi}</i>)
Air, Dry		2.9315×10^{-6}
Argon	(A)	4.0443×10^{-6}
Carbon Dioxide	(CO ₂)	4.4824×10^{-6}
Helium	(He)	4.0466×10^{-7}
Hydrogen	(H ₂)	2.0379×10^{-7}
Nitrogen	(N ₂)	2.8355×10^{-6}

HEAD PRESSURE CALCULATION

The pressure at the input port (P₂) of the Device Under Test (DUT) will be a positive number if the standard is positioned higher than the DUT. If the standard is lower than the DUT the head pressure correction will be a negative value. The equation used to calculate the head pressure for a gas medium is:

$$P_2 = P_1 (1 + h \times D_{psi})$$

h = Difference in vertical height between the center lines of the two pressure ports.

D_{psi} = Gas density (refer to the "Gas Density" table).

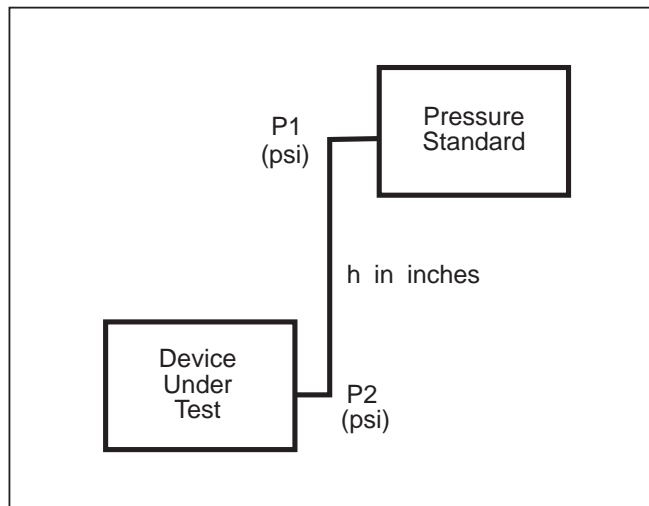

Figure 9.1 - Head Pressure Calculation

TABLE 9.6 – STANDARD SEA LEVEL PRESSURE AT VARIOUS ELEVATIONS

ELEVATION		PRESSURE UNITS					
Feet	Meters	psi	inH2O @4°C	inHg @0°C	Torr (or) mmHg@0°C	hPa (or) mBar	kPa
30000	9144.00	4.36410	120.80142	8.88542	225.68990	300.89429	30.08943
25000	7620.00	5.45352	150.95733	11.10351	282.02934	376.00715	37.60072
20000	6096.00	6.75340	186.93876	13.75009	349.25242	465.63081	46.56303
15000	4572.00	8.29351	229.57008	16.88579	428.89932	571.81715	57.18172
10000	3048.00	10.10644	279.75322	20.57696	522.65508	696.81420	69.68142
9000	2743.20	10.50483	290.78113	21.38811	543.25820	724.28270	72.42827
8000	2438.40	10.91585	302.15843	22.22495	564.51410	752.62149	75.26215
7000	2133.60	11.33980	313.89355	23.08812	586.43850	781.85153	78.18515
6000	1828.80	11.77698	325.99503	23.97823	609.04734	811.99409	81.19941
5000	1524.00	12.22771	338.47154	24.89593	632.35686	843.07082	84.30708
4000	1219.20	12.69231	351.33193	25.84186	656.38356	875.10370	87.51037
3000	914.40	13.17110	364.58516	26.81669	681.14420	908.11507	90.81151
2000	609.60	13.66441	378.24035	27.82108	706.65580	942.12764	94.21276
1000	304.80	14.17257	392.30675	28.85572	732.93567	977.16449	97.71645
900	274.32	14.22422	393.73637	28.96087	735.60658	980.72541	98.07254
800	243.84	14.27602	395.17020	29.06634	738.28537	984.29682	98.42968
700	213.36	14.32797	396.60826	29.17211	740.97206	987.87877	98.78788
600	182.88	14.38008	398.05055	29.27820	743.66666	991.47126	99.14713
500	152.40	14.43233	399.49709	29.38460	746.36918	995.07432	99.50743
400	121.92	14.48475	400.94788	29.49131	749.07965	998.68798	99.86880
300	91.44	14.53731	402.40294	29.59833	751.79809	1002.31225	100.23123
200	60.96	14.59003	403.86227	29.70567	754.52451	1005.94717	100.59472
100	30.48	14.64291	405.32588	29.81333	757.25894	1009.59276	100.95928
0	0	14.69594	406.79378	29.92130	760.00138	1013.24903	101.32490
-100	-30.48	14.74912	408.26598	30.02958	762.75185	1016.91603	101.69160
-200	-60.96	14.80246	409.74250	30.13819	765.51039	1020.59376	102.05938
-300	-91.44	14.85596	411.22333	30.24711	768.27699	1024.28225	102.42822
-400	-121.92	14.90961	412.70850	30.35635	771.05169	1027.98153	102.79815
-500	-152.40	14.96342	414.19801	30.46591	773.83449	1031.69162	103.16916
-600	-182.88	15.01739	415.69187	30.57579	776.62542	1035.41254	103.54125
-700	-213.36	15.07151	417.19008	30.68599	779.42450	1039.14433	103.91443
-800	-243.84	15.12580	418.69267	30.79651	782.23174	1042.88700	104.28870
-900	-274.32	15.18024	420.19964	30.90735	785.04716	1046.64057	104.66406
-1000	-304.80	15.23484	421.71099	31.01852	787.87078	1050.40508	105.04051
-1500	-457.20	15.51023	429.33394	31.57922	802.11253	1069.39246	106.93925
-2000	-609.60	15.78963	437.06809	32.14809	816.56201	1088.65681	108.86568
-2500	-762.00	16.07310	444.91467	32.72524	831.22156	1108.20121	110.82012
-3000	-914.40	16.36067	452.87493	33.31075	846.09349	1128.02876	112.80288

TABLE 9.7 – PRESSURE OFFSETS AT VARIOUS ELEVATIONS

ELEVATION		PRESSURE UNITS					
Feet	Meters	psi	inH2O @4°C	inHg @0°C	Torr (or) mmHg@0°C	hPa (or) mBar	kPa
30000	9144.00	10.33183	285.99236	21.03587	534.31148	712.35475	71.23547
25000	7620.00	9.24241	255.83645	18.81779	477.97204	637.24188	63.72419
20000	6096.00	7.94254	219.85502	16.17121	410.74895	547.61872	54.76187
15000	4572.00	6.40243	177.22370	13.03551	331.10205	441.43188	44.14319
10000	3048.00	4.58950	127.04056	9.34434	237.34630	316.43483	31.64348
9000	2743.20	4.19110	116.01265	8.53319	216.74318	288.96634	28.89663
8000	2438.40	3.78008	104.63534	7.69635	195.48727	260.62754	26.06275
7000	2133.60	3.35614	92.90023	6.83318	173.56288	231.39750	23.13975
6000	1828.80	2.91896	80.79875	5.94307	150.95404	201.25494	20.12549
5000	1524.00	2.46823	68.32224	5.02537	127.64451	170.17822	17.01782
4000	1219.20	2.00363	55.46185	4.07944	103.61781	138.14534	13.81453
3000	914.40	1.52484	42.20862	3.10461	78.85718	105.13397	10.51340
2000	609.60	1.03153	28.55343	2.10022	53.34558	71.12139	7.11214
1000	304.80	0.52336	14.48703	1.06558	27.06571	36.08455	3.60845
900	274.32	0.47172	13.05741	0.96042	24.39479	32.52363	3.25236
800	243.84	0.41992	11.62358	0.85496	21.71600	28.95221	2.89522
700	213.36	0.36796	10.18552	0.74919	19.02932	25.37027	2.53703
600	182.88	0.31586	8.74322	0.64310	16.33472	21.77778	2.17778
500	152.40	0.26360	7.29669	0.53670	13.63219	18.17471	1.81747
400	121.92	0.21119	5.84590	0.42999	10.92172	14.56106	1.45611
300	91.44	0.15862	4.39084	0.32296	8.20328	10.93678	1.09368
200	60.96	0.10590	2.93151	0.21562	5.47686	7.30186	0.73019
100	30.48	0.05303	1.46790	0.10797	2.74244	3.65628	0.36563
0	0	0.00000	0.00000	0.00000	0.00000	0.00000	0.00000
-100	-30.48	-0.05319	-1.47220	-0.10829	-2.75048	-3.66699	-0.36670
-200	-60.96	-0.10653	-2.94872	-0.21689	-5.50901	-7.34472	-0.73447
-300	-91.44	-0.16002	-4.42956	-0.32581	-8.27561	-11.03321	-1.10332
-400	-121.92	-0.21368	-5.91472	-0.43505	-11.05031	-14.73249	-1.47325
-500	-152.40	-0.26749	-7.40423	-0.54461	-13.83311	-18.44258	-1.84426
-600	-182.88	-0.32145	-8.89809	-0.65449	-16.62405	-22.16351	-2.21635
-700	-213.36	-0.37558	-10.39630	-0.76469	-19.42312	-25.89530	-2.58953
-800	-243.84	-0.42986	-11.89889	-0.87521	-22.23036	-29.63796	-2.96380
-900	-274.32	-0.48430	-13.40586	-0.98605	-25.04578	-33.39154	-3.33915
-1000	-304.80	-0.53890	-14.91721	-1.09722	-27.86941	-37.15605	-3.71560
-1500	-457.20	-0.81429	-22.54016	-1.65792	-42.11115	-56.14343	-5.61434
-2000	-609.60	-1.09370	-30.27431	-2.22680	-56.56064	-75.40777	-7.54078
-2500	-762.00	-1.37716	-38.12089	-2.80394	-71.22018	-94.95217	-9.49522
-3000	-914.40	-1.66474	-46.08115	-3.38945	-86.09211	-114.77973	-11.47797

TABLE 9.8 – CHASSIS DIP SWITCHES (Reference Figure 2.1)

	#	OFF	ON
S2 Rear Panel Functions and GPIB Addresses	1	Zero	Span
	2	Normal	Baro Change
	3	Normal	Sea Level Adjust
	4		GPIB Address 5
	5		GPIB Address 4
	6		GPIB Address 3
	7		GPIB Address 2
	8		GPIB Address 1

	#	OFF	ON
S3 Main oard Tests and Span Select	1		Configure Tests
	2		Configure Tests
	3		Configure Tests
	4		Configure Tests
	5		Not used
	6		Not used
	7		Not used
	8	Span Enable	Span Disable

	#	OFF	ON
S Main oard Resolution and Units Select	1	High Resolution	Low Resolution
	2		Set #2 Measurement Units
	3		Set #2 Measurement Units
	4		Set #2 Measurement Units
	5		Set #2 Measurement Units
	6		Set #2 Measurement Units
	7		Set #2 Measurement Units
	8		Set #2 Measurement Units

EIA-232 CABLE CONNECTIONS

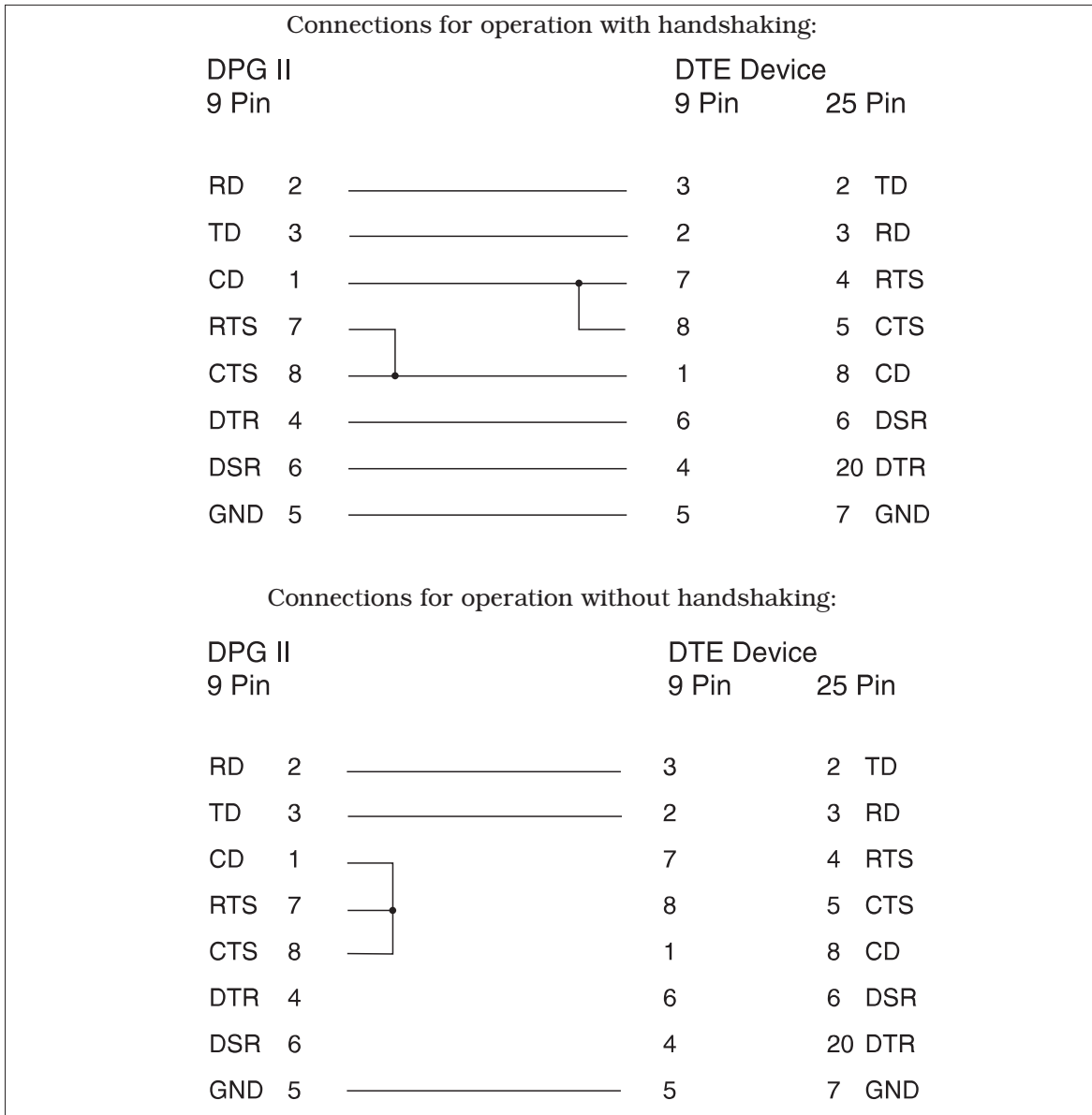

Figure 9.2 - EIA-232 Cable Connections

QUICK REFERENCE LIST OF COMMANDS

Table 9.9. – Quick Reference List of Commands

COMMAND	REF PAGES	QUERY	REF PAGES
C	5-11		
D (same as T)	5-11		
DEFAULT	5-5		
DIGITS	5-5	DIGITS?	5-5
DISPLAY	5-5	DISPLAY?	5-5
		DOC?	5-5
E	5-11	ERROR?	5-6
FILTER	5-6	FILTER?	5-6
		ID?	5-6
MASTER_CAL_ENABLE	5-6		
		OPT?	5-6
Q	5-12, 5-13		
		RANGENEG?	5-7
		RANGEPOS?	5-7
S	5-14		
SEA_LEVEL_ENABLE	5-7		
SEA_LEVEL	5-7	SEA_LEVEL?	5-7
SPAN	5-8	SPAN?	5-8
T	5-11		
TARE_CAL_ENABLE	5-9		
TARE	5-9	TARE?	5-9
		TYPE?	5-9

Continued on next page...

Table 9.9 continued...

COMMAND	REF PAGES	QUERY	REF PAGES
U	5-13		
UNITS	5-9	UNITS?	5-9
		UNITS_TABLE?	5-9
WINDOW	5-10	WINDOW?	5-10
Z	5-15		
ZERO_CAL_ENABLE	5-10		
ZERO	5-10	ZERO?	5-10

SAMPLE IEEE PROGRAM

The following is a sample program in Microsoft QuickBASIC that will read the DPG II output over the IEEE bus:

```

*****
' GENERAL PROGRAM DESCRIPTION

' This program demonstrates functions of the DPG-II's IEEE commands.
' IEEE address 3 is for the DPG-II under test. This program uses the
' National Instruments GPIB drivers. '
*****

      'this file has the IEEE driver calls for Nat. Inst. software
      ' $INCLUDE: 'QBDECL4.BAS'

      CLS

      ' * * * * * INITIALIZE EQUIPMENT * * * * *

      ' ASSUMES CONTROLLER BOARD 0 IS USED
      BDNAMES$ = "GPIB0"
      CALL IBFIND(BDNAMES$, BRD0%)
      IF BRD0% < 0 THEN PRINT "GPIB0 INITIALIZATION ERROR": STOP

      ' ASSUMES DPG-II WITH GPIB ADDR. #3
      BDNAMES$ = "DEV3": CALL IBFIND(BDNAMES$, BRD3%)
      IF BRD3% < 0 THEN PRINT "DPG-II INITIALIZATION ERROR": STOP

      ' * * * * * SET UP DPG-II * * * * *

      'Set output to be psi, standard output
      CALL IBWRT(BRD3%, "Q0X")
      CALL IBWRT(BRD3%, "U1X")

      'This program section reads the range and units from the DPG
      'and prints it to the screen
      CALL IBWRT(BRD3%, "Q3X")
      RD$ = SPACE$(50)
      CALL IBRD(BRD3%, RD$)
      PRINT RD$

```

'Now make 100 readings, 1 second apart and store elapsed time
'and the reading to disk

'Starting timer - note that this rolls over at midnight
START! = TIMER

FOR I = 1 TO 100

NOW! = TIMER: DO: LOOP UNTIL TIMER > NOW! + 1

'1 sec delay

RD\$ = SPACE\$(30): CALL IBRD(BRD3%, RD\$)

'This strips off the carriage return and line

'feed from the DPG string, one could have also

'returned VAL(RD\$) to do math on the DPG output.

DPG\$ = LEFT\$(RD\$, 7)

PRINT TIMER - START!; " "; DPG\$

OPEN "A:TESTDATA.PRN" FOR APPEND AS #1

PRINT #1, TIMER - START!; " "; DPG\$

CLOSE #1

NEXT

SYSTEM

User's Notes:

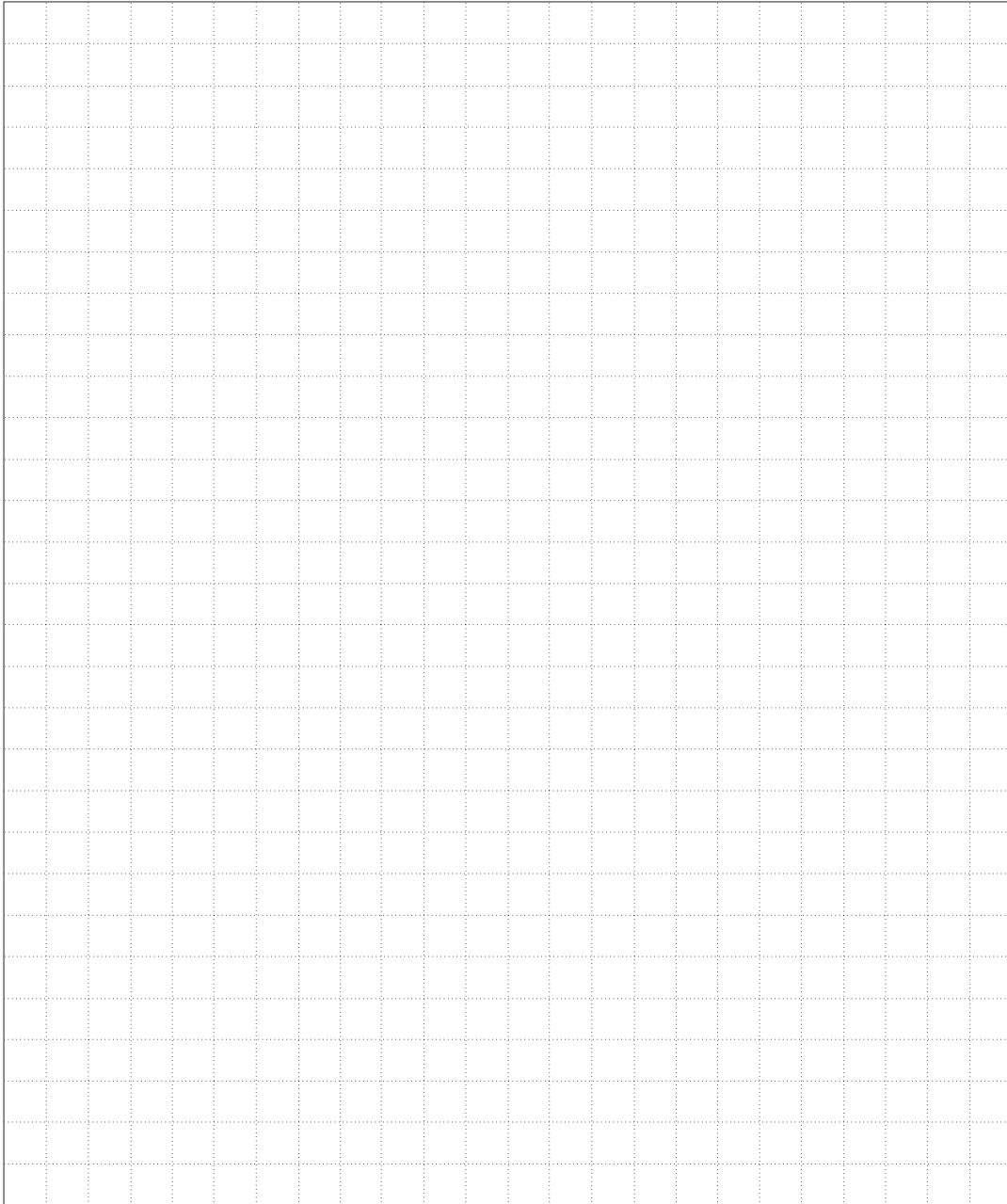
A large rectangular grid for user notes, consisting of 20 columns and 25 rows of small squares. The grid is empty and intended for handwritten notes.

GLOSSARY

Absolute Pressure

A pressure that is referenced to the absence of all other pressure, that is, referenced to true zero pressure. See *Pressure Relationships*.

Accuracy

The difference between the average of multiple measurements of a value and the true value. See *Uncertainty*.

Air Speed

The distance a body moves through the air per unit of time. Air speed is related to the free-stream total pressure (ram air pressure) and the static (or barometric) pressure.

Altitude

The vertical distance above mean sea level expressed in units of length (meters or feet). Mensor uses the ICAO Standard Atmosphere 1964 to relate absolute pressure (14.696145 psia) to altitude.

Altitude Rate

The change in altitude per unit time expressed as meters or feet per minute or per second.

Ambient Conditions

The conditions (pressure, temperature, etc.) surrounding the case of the instrument.

Attitude

The orientation of the instrument represented by its angles of inclination to three orthogonal axes.

Attitude Error

The error due to the orientation of the sensor relative to the direction in which gravity acts upon the sensor.

Barometric Pressure

Absolute atmospheric pressure at the point of measurement, frequently stated in terms of the height of a column of mercury. See *Pressure Relationships*.

Calibration

A test during which known values of pressure are applied to the instrument and corresponding output readings are recorded under specified conditions.

Calibration Curve

A graphical representation of the calibration points.

Calibration Cycle

The application of known values of pressure, and recording of corresponding output readings, over a full (or specified portion) of the range of an instrument in an ascending and descending direction.

Calibration Record

A record of the measured relationship of the instrument output to the applied pressure over the instrument range.

Calibration Traceability

The relationship of an instrument calibration, through a specified step-by-step process, to national standards or nationally accepted measurement systems through an unbroken chain of comparisons.

Calibration Uncertainty

The maximum calculated error in the output values, shown in a calibration record, due to causes not attributable to the instrument being calibrated.

Command Message

See *Interface Message*.

Compensation

An addition of specific materials, processes or devices to counteract a known cause of error.

Data Message

Same as Device Dependent Message.

DCL (Device Clear)

A GPIB interface message used to reset the internal functions of all devices on the bus.

Dead Band

The change through which the input to an instrument can vary without causing a change to the instrument output.

Device Dependent Message

A message sent from one device to another that is specific to that device, i.e., to set up parameters unique to that device or to transfer data.

Differential Pressure

The difference between the measured pressure and a fixed reference pressure. See *Pressure Relationships*.

Drift

Any change in output over a period of time, which change is not a function of the pressure being measured. See *Stability*.

EIA-232

A serial data communication path between instruments which conforms to the standards defined by ANSI/EIA 232-D-1986, "Interface Between Data Terminal Equipment (DTE) and Data Circuit-Terminating Equipment (DCE) Employing Serial Binary Data Interchange". Commonly known as EIA-232 (formerly RS-232), the standard is available from Electronic Industries Association, Engineering Dept., 2001 Eye Street N.W., Washington, D.C. 20006.

Elevation

The vertical height from mean sea level, especially of a point on the earth's surface, used in making local corrections to barometric readings.

Environmental Conditions

Specified external conditions (shock, vibration, temperature, etc.) to which an instrument may be exposed during shipping, storage, handling, and operation.

EOI

A GPIB line that is used to signal the end of a device dependent message.

Error

The algebraic difference between the indicated value and the true value of the pressure, usually expressed in percent of full scale.

FS

See *Full Scale*.

Full Scale

The upper limit of the device range, frequently noted as "FS".

Gauge Pressure

The difference between atmospheric pressure and a variable pressure. See *Pressure Relationships*.

GET (Group Execute Trigger)

A GPIB interface message that causes all devices with the GET capability and are currently addressed to listen to initiate a programmed action, for example to store the current reading, take a sweep on an oscilloscope, etc. The GET command provides a means of triggering multiple devices simultaneously.

GPIB (General Purpose Interface Bus)

A common name for the communication system defined in IEEE 488.1-1978. It is also known by the following names; IEEE 488.1, IEEE bus, HP-IB, ASCII bus, PLUS bus. The international version of the GPIB is defined in the IEC 625-1 standard, and is identical to the GPIB except for the connector.

GPIB Address

The address of a device on the GPIB, composed of a primary and possibly a secondary address. The DPG II does not support secondary addressing.

Gravity Correction

The correction factor applied to measurement processes involving mass to account for the gravity constant exerted at the site of the measurement.

GTL (Go To Local)

A GPIB interface message that causes the addressed listener(s) to go to the LOCAL (front panel) mode.

HP-IB (Hewlett-Packard Interface Bus)

Another name for the GPIB referring to the originator of the bus.

Hysteresis

The maximum difference in output, at any pressure value within the specified range, when the value is approached first with increasing and then decreasing pressure.

IEC 625-1

International version of the GPIB.

IEEE 488.1-1978

The standard defining the GPIB.

Interface Message

A message from the GPIB controller to all devices used to manage the bus and provide some control over the devices on the bus. See *Device Dependent Message*.

Linearity

The closeness of a calibration curve to a specified straight line expressed as a percentage of full scale deviation.

Line Pressure

The highest pressure within a system which can be present at the pressure sensor. See *Reference Pressure*.

Listener

A GPIB device that receives device dependent messages from a talker.

LLO (Local Lockout)

A GPIB interface message that causes all devices that respond to the Local Lockout command to ignore local control.

MLA (My Listen Address)

A GPIB interface message used to command a device to be addressed as a listener.

MTA (My Talker Address)

A GPIB interface message used to command a device to be addressed as a talker.

Operating Conditions

See *Environmental Conditions*.

Output

The electrical or digital quantity, produced by an instrument, which is a function of the applied pressure.

Over-pressure Rating

The pressure which may be applied to the sensing element or the case (as specified) of a sensor without damage to either the sensing element or sensor case as specified.

Parallel Poll

The process of polling all configured devices at once and returning a composite poll response. The *DPG II* does not support Parallel Polling. See *Serial Poll*.

Peak Pressure

The greatest (or if desired, the least) pressure sensed during a measurement session.

Precision

The ability of an instrument to repeat an output when measuring a given quantity under identical conditions.

Pressure Medium

The fluid (gas or liquid) which comes in contact with the sensing element in the pressure chamber.

Pressure Rate

An orderly change in pressure over a specified time.

Pressure Relationships

The relationship of various pressure terms are illustrated in the following graphic:

*** Standard Atmospheric Pressure:**

- Zero ft altitude
- 14.6961 psiA
- 29.9213 in.HgA @ 0°C
- 1013.250 millibars
- 760 mmHgA
- 760 torr
- 101.325 kilopascals
- 33.9602 ft.H₂O @ 20°C

* Values are approximate. Refer to Pressure Conversion Tables in the Appendix.

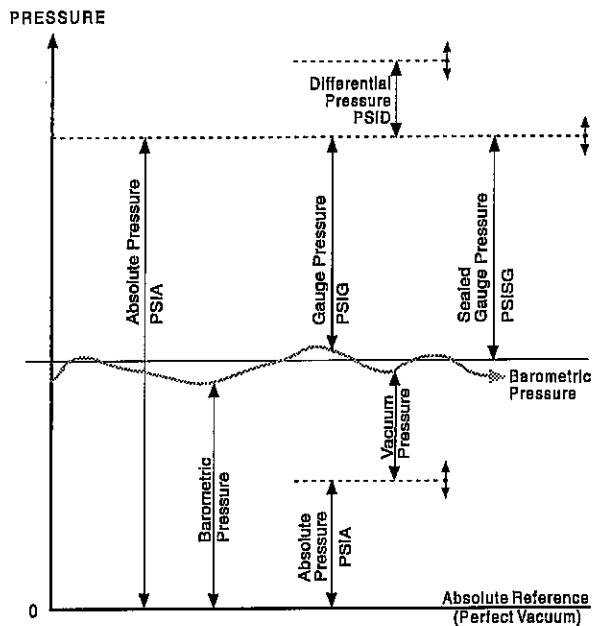

FIGURE 10.1 - PRESSURE RELATIONSHIPS

Range

The measurand values over which the measuring device is intended to measure, specified by the lower and upper limits. See also *Full Scale*.

Rate

See *Altitude Rate* or *Pressure Rate*.

Reference Pressure

The pressure relative to which a differential pressure instrument measures pressure.

Repeatability

The ability of an instrument to reproduce output readings when the same pressure value is applied repeatedly, under the same conditions, and in the same direction.

Resolution, Output

The maximum number of distinguishable values of output over the range of the instrument. Stated another way, the least detectable magnitude of change in the pressure.

Response Time

The length of time required for the output of the instrument to rise to a specified percentage of its final value as a result of a step change of pressure.

RS-232

See *EIA-232*.

SDC (Selected Device Clear)

A command used to reset the internal functions of an addressed listener.

Serial Poll

The process of polling and reading the status of one specified device on the bus.

Span

The algebraic difference between the lower and upper limits of the range.

SRQ (Service Request)

A GPIB line that a device asserts to notify the controller that the device needs service.

Stability

The ability of an instrument to retain its performance characteristics for an extended period of time.

Status Byte

The data byte sent by a device when it is serially polled.

Talker

A GPIB device that sends device dependent messages to listeners.

Temperature Error

The maximum change in output, at any pressure value within the specified range, when the transducer temperature is changed from the nominal compensated temperature (mid-range of the stated compensated temperature range) to the compensated temperature extremes.

Temperature Range, Compensated

See *Temperature Range, Operating*.

Temperature Range, Operating

The range of ambient temperatures within which the instrument is intended to operate.

Uncertainty

The maximum credible limits for the difference between the true value and the measured value of the pressure under consideration.

Vacuum Pressure

A pressure less than ambient barometric pressure. See *Pressure Relationships*.

Warm-up

The period of time from the application of power until the instrument has reached its operating temperature, required to assure that the instrument will perform within all specified tolerances.

Zero Drift

A change in the zero-pressure output over a specified period of time.

INDEX

A

Address 5-2
 Altitude 4-4, 5-16
 Altitude Rate Option 7-2
 Analog Output 8-9
 Uncertainty 7-1
 Analog/BCD Output 8-1, 8-8
 Pin Assignments 8-10
 Appendix 9-1 - 9-17
 Attitude Error 7-3
 Automotive Power Cord 8-1

B

Baro Change Switch 4-3
 Battery Charger 8-3
 Battery Pack, Rechargeable 8-2
 Illustration 8-2
 Baud Rate 8-7 - 8-8
 BCD Output 8-10

C

C Command 5-11
 Cable, EIA-232 9-13
 Calibrating the DPG II Barometer 6-2
 Calibration
 Environment 6-1
 Medium 6-2
 Setup 6-2
 Standard 6-2
 Standard Uncertainty 7-2
 Carrying Case 8-5
 Chassis DIP Switches 9-12
 Compensated Temperature Range 7-2
 Configuration Switches 2-1
 Configuration, System 2-1 - 2-8, 2-10
 Connections, Pressure 7-4
 Conversion Factors, millitorr 9-4
 Conversion Factors, psi 9-2
 Conversion Table, Temperature 9-6
 Correction Value Query 6-6
 Correction, Head Pressure 9-8

D

D Command	5-11
DCL	5-3
Decimal Codes	8-12
Device Address	5-2
Device Clear (DCL)	5-3
Device Dependent Messages	5-4
Digital Output Uncertainty	7-1
Display	4-1, 7-4
Configuration	2-8
Custom	4-1

E

E Command	2-3
EIA-232	
Cable Connections	9-13
Interface	5-1
Options	8-1
Serial Communication Port	8-6
Switch Settings	8-7
Engineering Units	5-13
<i>see also</i> Measurement Units	
EOI	5-13
Error	4-1, 5-13
Error Conditions and Suggested Actions	3-2

F

FCC Radio Frequency Emission Note	ii
Fittings, Adaptor	3-1, 7-4
Fuse	6-1, 7-4

G

Gas Density	9-8
GET	5-3
Glossary	10-1 - 10-8
GPIB	5-1
Address	2-5, 5-2
Group Execute Trigger (GET)	5-3
GTL (Go to Local)	5-3

H

Handle Kit 8-4
 Head Pressure Calculation 9-9
 Head Pressure Correction 9-8
 Hourly Barometric Change 4-2, 7-2

I

IEEE 488.1-1987 Interface Bus 7-4
 IEEE Capability Codes 5-1
 IEEE Sample Program 9-16
 Illustration of Instrument
 Front View 1-4
 Rear View 1-4
 Initialization 1-2
 Instrument Uncertainty 7-1
 Introduction 1-1 - 1-4

L

L Command 4-4
 Liquid Density 9-9
 LLO 5-1
 Local Lockout (LLO) 5-1 - 5-2
 Local Operation 4-1 - 4-4
 Local Span Adjustment 6-4
 Local Zero Adjustment 6-4

M

Maintenance and Calibration 6-1
 Materials in Contact with Pressure Medium 9-7
 Measurement Error due to Temperature Change 7-2
 Measurement Units 2-3, 5-13 - 5-14
 Message Set, Expanded 5-4
 Mounting 7-4
 My Listen Address (MLA) 5-1
 My Talker Address (MTA) 5-1

O

Operating Environment 7-3
 Operation
 Remote 5-1 - 5-16

Optional Outputs 7-3
 Options 8-1 - 8-13
 Output Mode 2-3
 Output Resolution 2-8, 7-3
 Outputs 7-2 - 7-4
 Over Pressure Rating 7-3

P

Packaging for Shipment iv
 Password
 MASTER_CAL_ENABLE 5-6, 5-8
 TARE_CAL_ENABLE 5-9
 ZERO_CAL_ENABLE 5-10
 Power 7-4, 8-1
 Power On 3-1
 Power Up 1-2
 Pressure
 Medium 7-1, 9-7
 Ranges 7-1
 Rate 5-14
 Pressure Connection 7-4
 Pressure Offsets at Various Elevations 9-11
 Pressure Standard Uncertainty 7-2

Q

Q Command 4-4, 6-6, 5-12 - 5-13

R

Rack Mount 8-1
 Ranges 7-1
 Remote Command Quick Reference 9-14
 Remote Operation 4-4, 5-1 - 5-16
 Remote Span Adjustment 6-5
 Remote Transducer 8-1
 Remote Zero Adjustment 6-4
 Resolution, Output 2-8, 7-2
 Response Time 7-3
 RL (Listener) 4-1
 RT (Talker) 4-1

S

S Command (Span) 5-14, 6-5
 SDC 5-3
 Sea Level Adjustment 4-3 - 4-4
 Sea Level Pressure at Various Elevations 9-1, 9-10
 Selected Device Clear (SDC) 5-3
 Serial Poll 5-3
 Service Request Line (SRQ) 5-2, 5-4
 Setup 2-3
 Shipping, Storage and Handling 7-4
 Size 7-5
 Software License Agreement iv
 Span Adjustment, Local 6-4
 Span Adjustment, Remote 6-5
 Specifications 7-1 - 7-5
 SRQ (Service Request Line) 5-2, 5-4
 Standard, Calibration 6-2
 Status Display 5-2
 Switches, Chassis DIP 9-12
 Switches, Configuration 2-1

T

Temperature Conversion 9-6
 Temperature Error 7-2
 Temperature Range, Compensated 7-2
 Terse Message Set 5-11
 Test Modes 2-7
 Trademarks iv
 Transducer
 Remote 8-1
 Uncertainty 7-1
 Volume 7-6

U

U Command (Units) 4-4, 5-14
 Uncertainty
 Altitude Pressure Units Correction 7-2
 Analog Output 7-2
 Calibration Standard 7-2
 Digital Output 7-2
 Local Elevation Correction 7-2
 Measurement Error due to Temp Change 7-2
 Transducer 7-1
 Units Codes 8-12
 Units Selection 2-4

V

Volume, Transducer 7-6

W

Warm-up 7-3

Span Drift 7-3

Zero Drift 7-3

Warnings and Caution Notes iii, 6-1

Warranty ii

Weight 7-5

X

X Command Termination 3-3

Z

Z Command (Zero) 5-15, 6-5

Zero Adjustment, Local 6-4

Zero Adjustment, Remote 6-4