

Optoelectronic level switch and switching amplifier

For the process industry

Models OLS-2, OSA-SC

WIKA data sheet LM 31.07

for further approvals,
see page 3

Applications

- Cryogenic applications (liquid gas)
- Chemical industry, petrochemical industry, natural gas, offshore
- Shipbuilding, machine building, refrigerator units
- Power generating equipment, power plants
- Process water and drinking water treatment

Special features

- Temperature ranges from -269 ... +400 °C
[-452 ... +752 °F]
- Versions for pressure ranges from vacuum to 500 bar
[7,252 psi]
- Special versions: High pressure, interface measurement
- Explosion-protected versions
- Signal processing is made using a separate model
OSA-SC switching amplifier

Description

The model OLS-2 optoelectronic level switch is used for the detection of limit levels in liquids. The OLS-2 operates widely independent of physical characteristics such as refractive index, colour, density, dielectric constant and conductivity. Measurement of level change is also done in small volumes.

The model OLS-2 limit level switch consists of an infrared LED and a phototransistor. The light of the LED is directed into a prism. So long as the sensor tip of the prism is in the gaseous phase, the light is reflected within the prism to the receiver. When the liquid in the vessel rises and wets approximately 2/3 of the glass tip, the infrared light beam into the liquid is interrupted and only a small portion reaches the receptor.



Fig. left: Model OLS-2, optoelectronic level switch
Fig. right: Model OSA-SC, switching amplifier with Bluetooth® function

This difference is evaluated by the electronics and triggers a switching operation.

The instruments are very robust and designed for rough operating conditions. The installation position can be as required. Thus, the OLS-2 can be installed from above, from below, vertically, horizontally or at an angle.

The cable to the model OSA-SC switching amplifier does not need any shield, enabling easy and economic cabling. The change in the alarm direction, the sensitivity of the switching threshold, as well as a time delay of up to 8 seconds can be easily transferred to the OSA-SC via Bluetooth® app and changed individually.

Specifications

Optoelectronic level switch Model OLS-2A, OLS-2AI

Specifications	
Measuring length (switch point) ML	<ul style="list-style-type: none"> 25 mm [0.98 in] With extension of the light guide 35 ... 960 mm [1.38 ... 37.80 in]
Insertion length IL	29 mm [1.14 in] (ML + 4 mm [0.16 in])
Medium temperature	Standard version without cooling element -65 ... +170 °C [-85 ... +338 °F] High-/Low-temperature version with cooling element -269 ... +400 °C [-452 ... +752 °F]
Ambient temperature	-55 ... +80 °C [-67 ... +176 °F]
Storage temperature	-20 ... +80 °C [-4 ... +176 °F]
Pressure range	-1 ... +500 bar [-14.50 ... +7,252 psi] depending on p/T rating (pressure/temperature assignment)
Measurement type	<ul style="list-style-type: none"> Level measurement with glass tip V shape Interface layer with glass tip U shape
Process connection	
Mounting thread	<ul style="list-style-type: none"> G ½, Außengewinde ½ NPT, Außengewinde
Process connection flange	<ul style="list-style-type: none"> ½" ... 2" per ASME B16.5 DN20 ... DN50 per DIN EN 1092-1
Light guide	<ul style="list-style-type: none"> Clad core glass (ML: max. 900 mm [35.43 in]) Fused quartz (ML: max. 200 mm [7.87 in]) Sapphire glass (ML: max. 60 mm [2.36 in])
Mounting position	As required
Measurement accuracy	±0.5 mm [± 0.02 in]
Repeat accuracy	±0.1 mm [± 0.04 in]
Light source	IR light 930 nm
Protection of the light guide	Metal protective housing with lateral opening slots
Ambient light	Max. 100 Lux
Material	
Case	Stainless steel 1.4571
Light guide (wetted)	<ul style="list-style-type: none"> Stainless steel 1.4571 Hastelloy Other materials on request
Cable gland	M20 x 1.5
Terminal connection	
Termination point	4-pin SMD PCB terminal
Single-wire/fine-wired conductor	0.5 ... 1.5 mm ² / 20 ... 16 AWG
Fine-wired conductor with end splice with/without plastic collar	0.5 ... 0.75 mm ²
Ingress protection per IEC/EN 60529	<ul style="list-style-type: none"> IP66 IP68

Bluetooth capable switching amplifier for optoelectronic level switches Model OSA-SC, OSA-SCI

Specifications	
Ambient temperature	-20 ... +60 °C [-4 ... +140 °F]
Storage temperature	-20 ... +60 °C [-4 ... +140 °F]
Auxiliary power	DC 12 ... 30 V, protected against reverse polarity
Power dissipation / Power consumption	≤ 0.9W
Output	Change-over contact (SPDT)
Max. connection cross-section	2.5 mm ²
Max. cable length	175 ... 600 m [574.1 ... 1,968.5 ft] (for 0.5 ... 1.5 mm ²)
Ingress protection per IEC/EN 60529	IP20
Dimensions	29 x 130 x 127 mm [1.14 x 5.12 x 5 in] (W x H x D)
Mounting	On 35-mm DIN rail per EN 60715:2015

General data	
Functions	<ul style="list-style-type: none"> Alarm direction selectable for high or low alarm Pick-up delay and drop-out delay settable up to 8 seconds for signal relay
Monitoring	<ul style="list-style-type: none"> Wire break signal circuit Short-circuit signal circuit Internal auxiliary power, fail-safe Green status LED for auxiliary power monitoring Yellow status LED for alarm monitoring (switched relay)

Switching amplifier

Model	Article number
OSA-SC (standard version)	14602554
OSA-SCI (Ex i version)	14602553

Approvals

Logo	Description	Region
	EU declaration of conformity EMC directive EN 61326 emission (group 1, class B) and immunity (industrial environments)	European Union
	UKCA Electromagnetic compatibility regulations	United Kingdom

Optional approvals

Logo	Description	Region
	EU declaration of conformity ATEX directive Hazardous areas - Ex i Zone 1 mounting to zone 0 gas II 1/2G Ex ib IIC T6 ... T1 Ga/Gb Zone 21 dust II 2D Ex ib IIIC T85 ... T400 °C Db	European Union
	IECEx Hazardous areas - Ex i Zone 1 mounting to zone 0 gas Ex ib IIC T6 ... T1 Ga/Gb Zone 21 dust Ex ib IIIC T85 ... T400 °C Db	International

→ For approvals and certificates, see website

Overview of versions

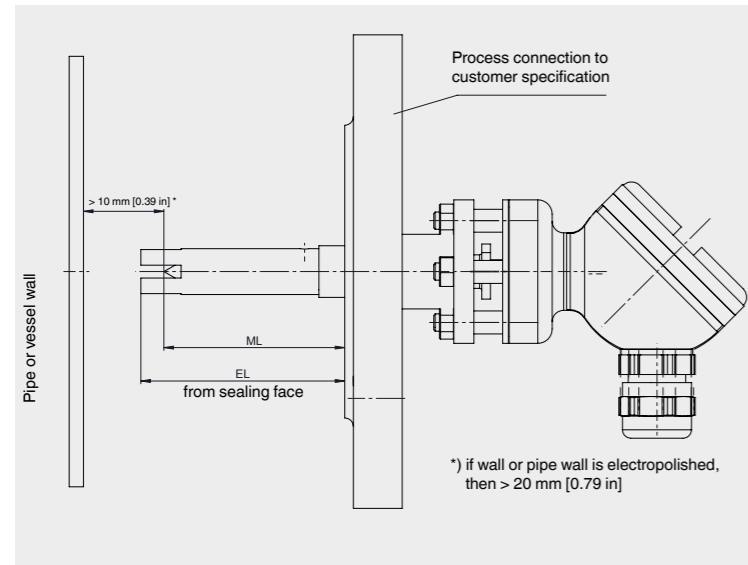

Mounting thread with cooling element

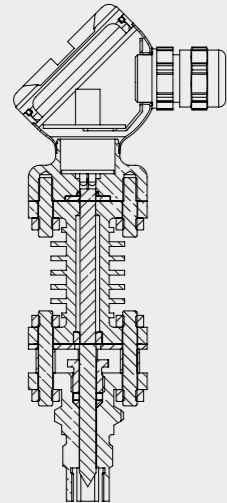

Mounting thread without cooling element

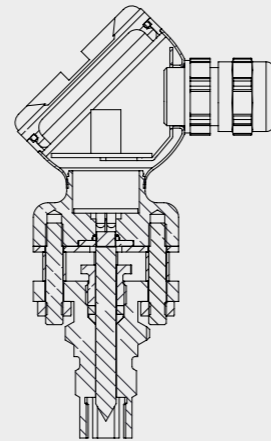

Flange version with cooling element

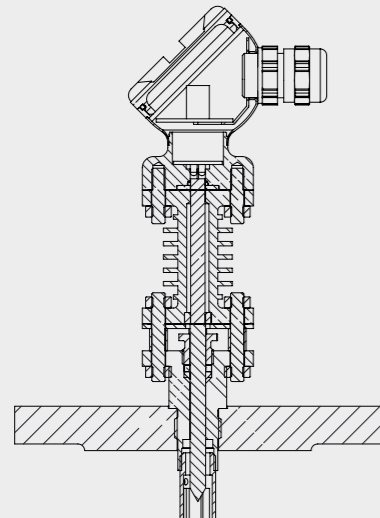

Flange version without cooling element

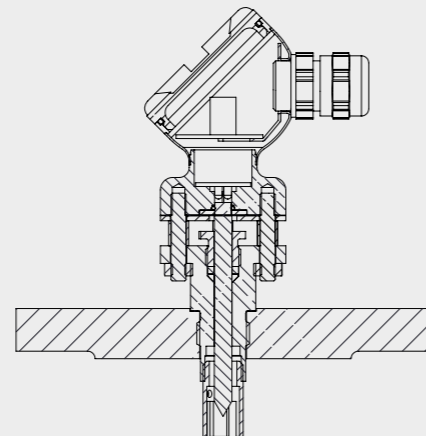

Version with sieve

Protection from gas bubble formation at the glass tip

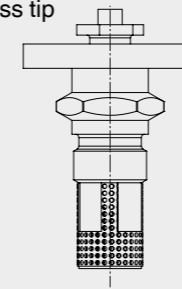

Version for interface layer

Open glass tip, shape U

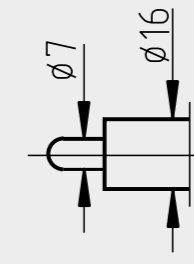

Electrical connection diagram

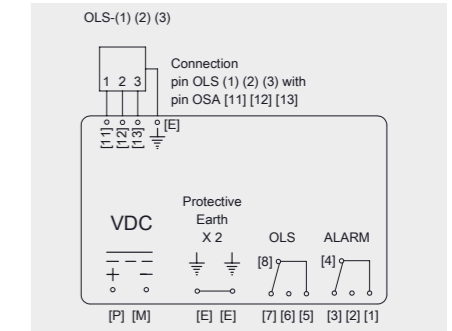

App for Bluetooth® configuration

Via the app, the switching amplifier unit (OSA-SC, OSA-SCI) can be conveniently connected with a smartphone over Bluetooth® Low Energy (BLE).

One calls up the configuration as follows:

Start the app on the end device (e.g. smartphone) and establish a wireless connection via Bluetooth®.

Press the "SetEasy" button on the front of the switching amplifier for 3 seconds.

A message now appears on the smartphone that the system is switching from measuring mode to configuration mode.

In addition to the graphical representation of the switching status, the instrument status and the instrument temperature are also displayed. The instrument description, TAG number, switching direction and switching delay (0...8 seconds) can easily be individually configured via the app.



For iOS-based smartphones, the app is available in the Apple Store via the link below.

[Download here](#)



For smartphones with an Android operating system, the app is available in the Play Store via the link below.

[Download here](#)



Publisher: A puissance 3 mesure industrielle

Ordering information

To order the described product the order number is sufficient.

Alternatively:

Level switch: Model / Process connection / Measurement type / Measuring length (switch point) ML / Process specifications (operating temperature and pressure) / Material / Light guide material / Sieve

Switching amplifier: Model / Case / Auxiliary power

© 05/2023 WIKA Alexander Wiegand SE & Co. KG, all rights reserved.
The specifications given in this document represent the state of engineering at the time of publishing.
We reserve the right to make modifications to the specifications and materials.

