

Level sensor With reed-chain technology Model FLR for nuclear power plants

KSR data sheet FLR for NPP



Applications

- Level measurement for almost all liquid media
- Chemical, petrochemical, natural gas, offshore, shipbuilding, machine building, power generating equipment, power plants
- Process water and drinking water treatment, food industry, pharmaceutical industry

Special features

- Process- and system-specific solutions possible
- Operating limits:
 - Operating temperature: $T = -80 \dots +200 \text{ }^\circ\text{C}$
 - Operating pressure: $P = \text{Vacuum to } 80 \text{ bar}$
 - Limit density: $\rho \geq 400 \text{ kg/m}^3$
- Wide variety of different electrical connections, process connections and materials
- Optionally with programmable and configurable head-mounted transmitter for 4 ... 20 mA field signals, HART®, PROFIBUS® PA and FOUNDATION™ Fieldbus
- Explosion-protected versions

Description

The model FLR sensors with reed-chain technology are used for level measurement in liquid media. They work on the float principle with magnetic transmission.

The float's magnetic system in the guide tube actuates a resistance measuring chain that corresponds to a 3-wire potentiometer circuit. The measurement voltage generated by this is proportional to the fill level.

The measurement voltage is very finely-stepped due to the contact separation of the measuring chain and is thus virtually continuous. Resolutions between 5 and 18 mm are available depending on the requirements.



Level sensor with reed-chain technology,
model FLR-S, flange connection

Further special features

- Large scope of application due to the simple, proven functional principle
- Process connection, guide tube and float from stainless steel 1.4571 or plastic
- For harsh operating conditions, long service life
- Continuous measurement of levels, independent of physical and chemical changes of the media such as: Foaming, conductivity, dielectric, pressure, vacuum, temperature, vapours, condensation, bubble formation, boiling effects, density change
- Signal transmission over long distances
- Simple installation and commissioning, onetime calibration only, no recalibration necessary
- Level displayed proportional to volume or height
- High repeatability
- Interface measurement and overall level from Δ density 50 kg/m³
- Level sensors with reed-chain technology qualify as passive electrical equipment in accordance with DIN IEC 60079-11 and can be installed in "zone 1" hazardous areas without certification, so long as the equipment is operated in a certified intrinsically safe circuit with a minimum explosion protection of EEx ib.

Options

- Customised solutions
- Programmable and configurable head-mounted transmitters in connection housing, output signal 4 ... 20 mA, 2-wire, for HART®, PROFIBUS® PA and FOUNDATION™ Fieldbus
- Process connection, guide tube material and float from stainless steel 1.4435, 1.4539, titanium, Hastelloy (others on request)
- In combination with limit switch, stepless setting of the limit values over the entire measuring range

Internal circuit diagram of the reed sensors

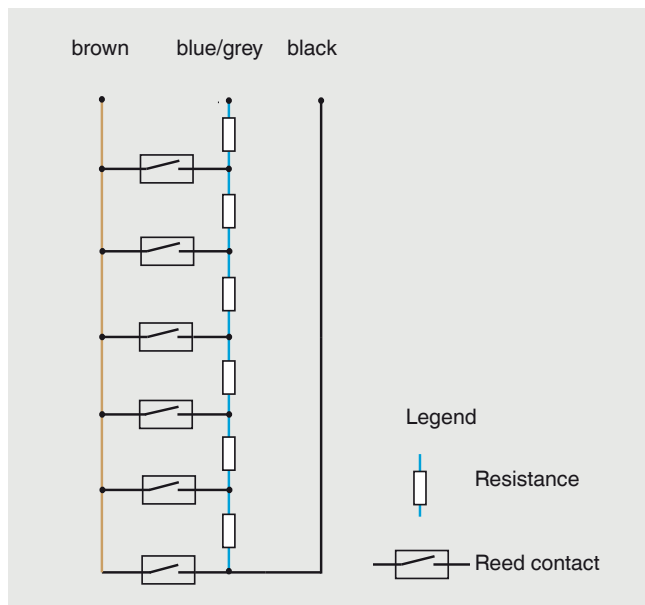

Model overview

Sensor model	Description	Materials										
		Stainless steel						Titanium	PVC	PP	PVDF	Buna
		1.4571 (316Ti)	1.4404 (316L)	1.4435 (316L)	1.4571 (316Ti)	1.4571 (316Ti)	1.4571 (316Ti)	3.7035 (grade 2)				
FLR-S	Reed-chain sensor, standard version	x	x	x	x	x	x	x				x

Sensor model	Approval											Temperature range (process)
	without	Ex i	Ex d	GL	Ex i + GL	ABS	DNV	Bureau Veritas	3-A	FM	GOST	
FLR-S	x	x	x	x	x	x	x	x		x		-80 ... +200 °C

Ex approvals

Explosion protection	Ignition protection type	Model	Zone	Approval number
ATEX	Ex i	FLR-S	Zone 0/1/2	KEMA 01 ATEX 1152 X II 1/2G Ex ia IIC T4 ... T6 - II 2 D T80 °C IP 6X TÜV 13 ATEX 7399 X II 2G Ex d IIC T6 Gb / II 2 D Ex tb IIIC T80 °C Db
	Ex d	FLR-S	Zone 1/2	
	Ex i + GL	FLR-S	Zone 1/2	KEMA 01 ATEX 1152 X II 1/2G Ex ia IIC T4 ... T6 - II 2 D T80 °C IP 6X + GL-14788-99 HH
	Ex i + DNV	FLR-S	Zone 1/2	KEMA 01 ATEX 1152 X II 1/2G Ex ia IIC T4 ... T6 - II 2 D T80 °C IP 6X + DNV-A-11452

Type approval

Explosion protection	Model	Approval number
GL	FLR-S	GL-14788-99 HH
DNV	FLR-S	DNV-A-11452
GOST	FLR-S	0959333

Sensor, standard version, model FLR-S

Process connection, guide tube material and float from stainless steel 1.4571

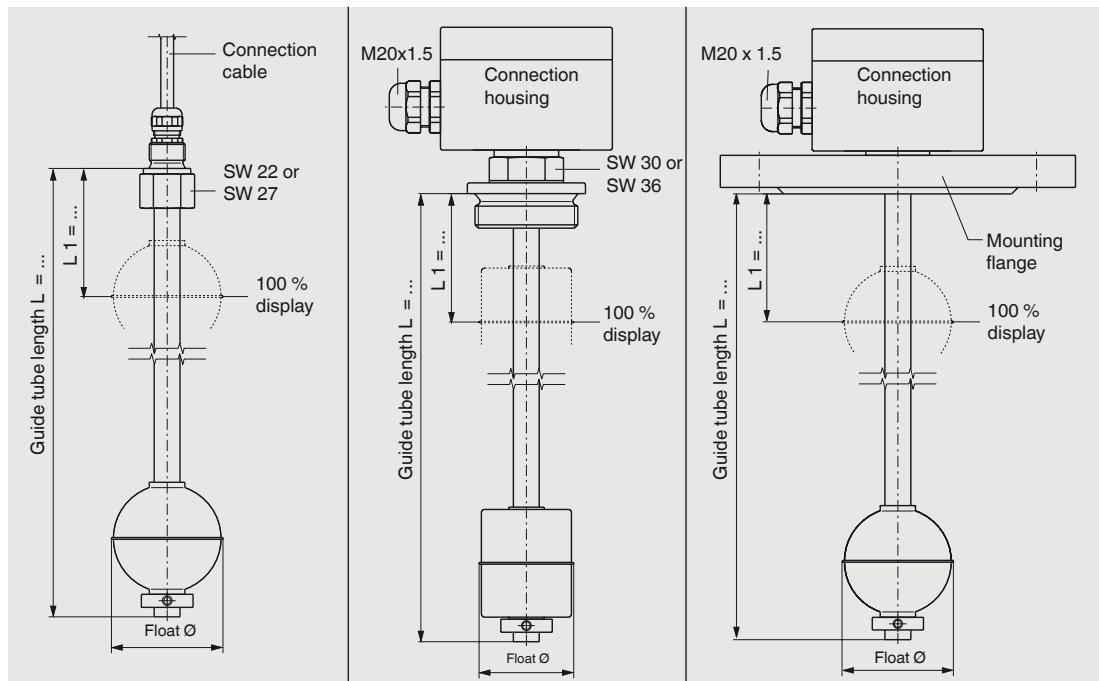

	Mounting thread (without connection housing)			Mounting thread			Flange			
Electrical connection	Connection cable ■ PVC ■ Silicone ■ PUR			Connection housing ■ Aluminium 80 x 75 x 57 mm Option: Polypropylene, polyester, stainless steel						
Process connection	Mounting thread upwards G 3/8" (others on request)		G 1/2" (others on request)	Mounting thread downwards G 1 1/2" or G 2"			Mounting flange ■ DIN DN 50 ... DN 200, PN 6 ... PN 100 ■ ANSI 2" ... 8", class 150 ... 600			
Guide tube diameter	8 mm	12 or 14 mm	18 mm	8 mm	12 or 14 mm	18 mm	8 mm	12 or 14 mm	18 mm	30 mm
Guide tube length L max.	500 mm	3,000 mm	6,000 mm	500 mm	3,000 mm	6,000 mm	500 mm	3,000 mm	6,000 mm	15,000 mm
Float	Material stainless steel 1.4571 (Option: Buna, titanium) Float diameter from 44 ... 120 mm Float selection depending on guide tube diameter and process conditions									
Max. operating pressure	80 bar, see table for floats (K) and (Z)									
Temperature range standard	PVC-/PUR cable -10 ... +80 °C Silicone cable -10 ... +120 °C		-20 ... +120 °C Option: ■ High-temperature version: +120 ... +200 °C Option: ■ Low-temperature version: -80 ... -20 °C							
Contact separation	K 18 = 18 mm (not with option high and low temperature version) K 15 = 15 mm K 10 = 10 mm K 5 = 5 mm									
Overall resistance of the measuring chain	Length and separation dependent									
Connection cable to transmitter	3-wire, screened									
Mounting position	Vertical ±30°									
Ingress protection	IP 65 per EN 60529 / IEC 60529									
Materials	Stainless steel 1.4571, 1.4404, 1.4435, 1.4439, titanium 3.7035 (grade 2), Hastelloy and others on request									

Nuclear qualified plug (Han® 7D) on request.

Sensor, explosion-protected version, intrinsically safe, model FLR-S

KEMA 01 ATEX 1052 X II 1/2G Ex ia IIC T4 ... T6 - II 2 D T80 °C IP 6X

Process connection, guide tube and float from stainless steel 1.4571

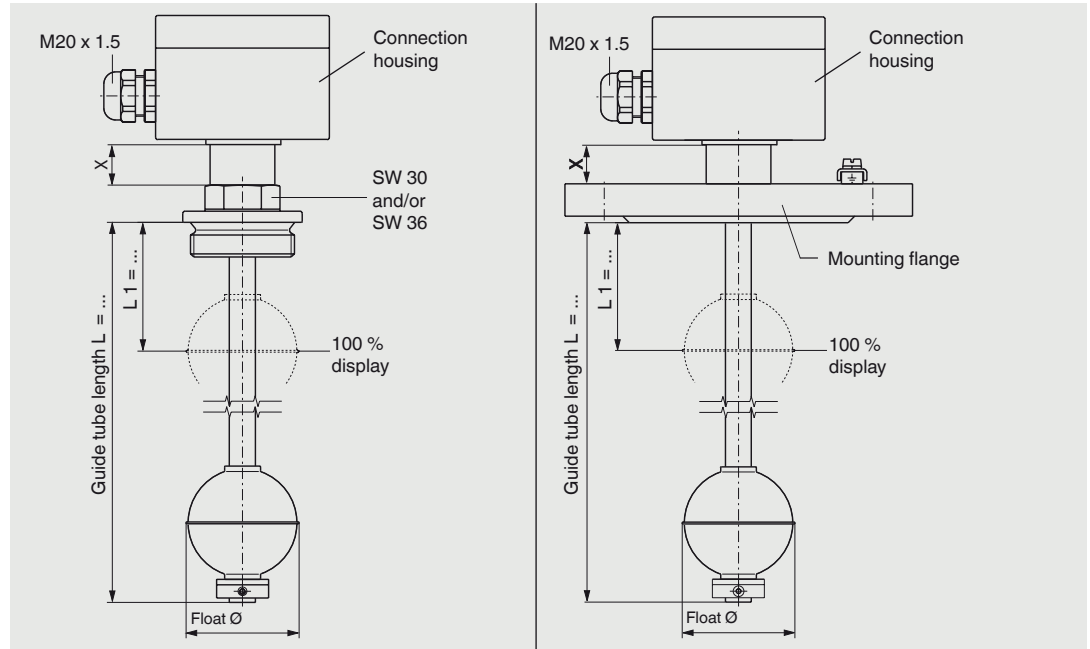

Mounting thread		Flange	
Electrical connection	Connection housing ■ Aluminium 80 x 75 x 57 mm Option: Stainless steel, polyester		
Process connection	Mounting thread downwards G 1 1/2" or G 2" (others on request)	Mounting flange ■ DIN DN 50 ... DN 200, PN 6 ... PN 100 ■ ANSI 2" ... 8", class 150 ... 600	
Guide tube diameter	12, 14 or 18 mm		
Guide tube length L max.	See variants A and B		
Float	Material stainless steel 1.4571 (Option: Buna, titanium) Float diameter from 44 ... 120 mm Float selection depending on guide tube diameter and process conditions		
Max. operating pressure	see table for floats (K) and (Z)		
Temperature class	T4	T5	T6
Surface temperature	Max. 135 °C	100 °C	85 °C
Process temperature	Max. 100 °C	65 °C	50 °C
Ambient temperature at connection housing	Max. 60 °C	60 °C	60 °C
Contact separation	K 18 = 18 mm K 15 = 15 mm K 10 = 10 mm K 5 = 5 mm		
Overall resistance of the measuring chain	Length and separation dependent		
Control circuit	Ignition protection type EEx ia IIC, only for connection to a certified intrinsically safe control circuit Transmitter external with max. 120 mA, max. 28 V Head-mounted transmitter in accordance with transmitter approvals		
Connection cable to transmitter	Cable length max. 2,000 m, 3-wire, screened		
Mounting position	Vertical ±30°		
Ingress protection	IP 65 per EN 60529 / IEC 60529		
Materials	Stainless steel 1.4571, 1.4404, titanium 3.7035 (grade 2), Hastelloy and others on request		

Nuclear qualified plug (Han® 7D) on request.

Spherical floats (K)

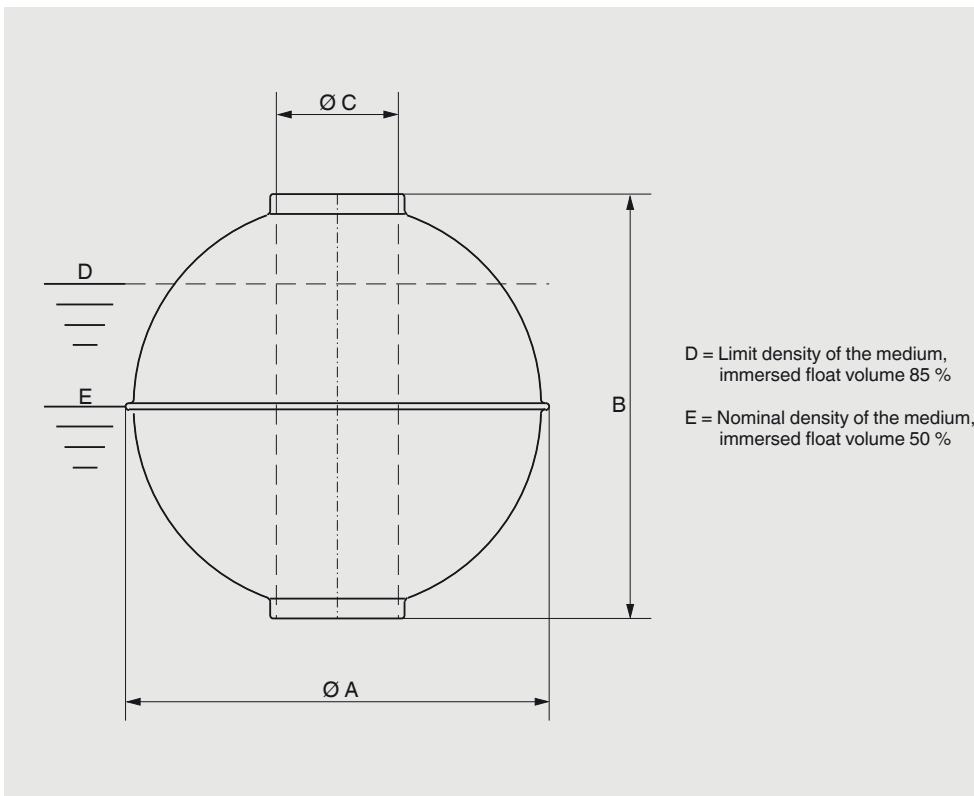

Material	Suits guide tube \varnothing mm	$\varnothing A$ mm	B mm	$\varnothing C$ mm	Max. operating pressure bar	Max. operating temperature °C	Limit density 85 % kg/m ³
Stainless steel 1.4571	12	52	52	15	40	250	727
	12	62	61	15	32	250	597
	12	83	81	15	25	250	412
	18	80	76	23	25	250	617
	18	98	96	23	25	250	561
	18	105	103	23	25	250	520
	18	120	117	23	25	250	394
	18-30	120	116	38	25	250	537
	18-30	200	192	56	16	250	581
Titanium 3.7035	12	52	52	15	25	250	623
	12	52	52	15	60	250	790
	12	52	52	15	80	250	997
	12	62	62	15	25	250	482
	12	83	81	15	25	250	343
	18	80	76	23	25	250	866
	18	98	96	23	25	250	536
	18	105	103	23	25	250	416
	18	120	117	23	25	250	315
Stainless steel 1.4571	18	81	77	22	25	depending on medium	634

Note: The optimum float will be selected after a feasibility test carried out by KSR.

Cylindrical floats (Z)

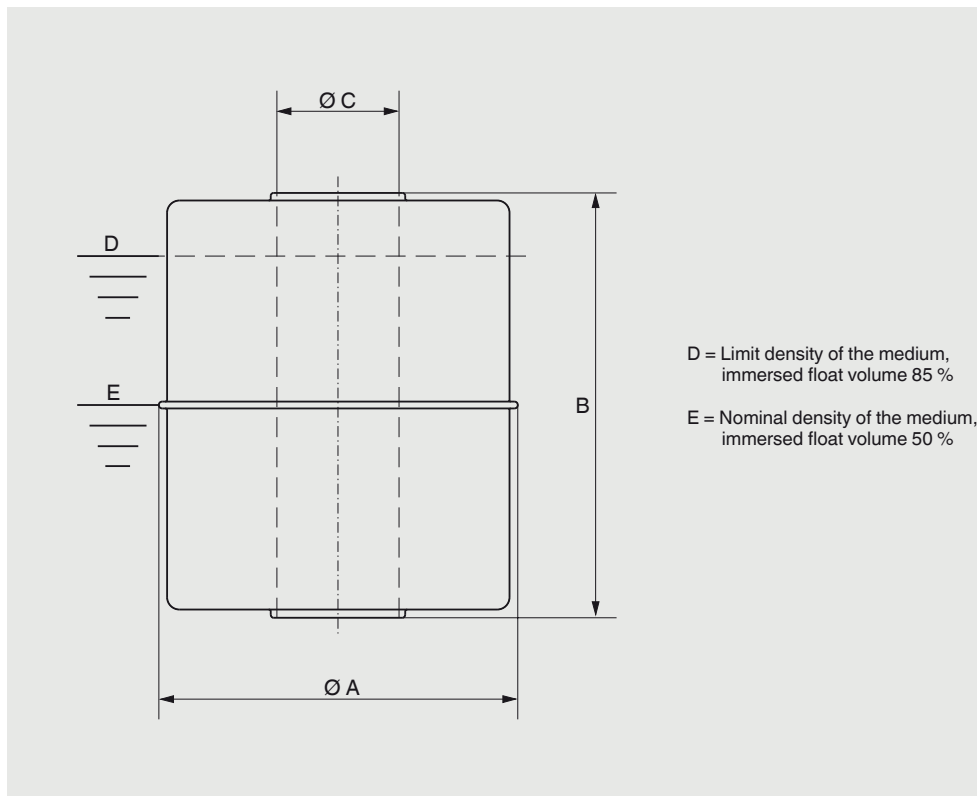

Material	Suits guide tube \varnothing mm	$\varnothing A$ mm	B mm	$\varnothing C$ mm	Max. operating pressure bar	Max. operating temperature °C	Limit density 85 % kg/m ³
Stainless steel 1.4571	12	44	52	15	16	250	740
Titanium 3.7035	12	44	52	15	16	250	645

Note: The optimum float will be selected after a feasibility test carried out by KSR.

Determination of the max. guide tube length L for explosion-protected version, intrinsically safe

Version A: Fixed to the tank ceiling

Version B: Fixed to the tank ceiling and floor

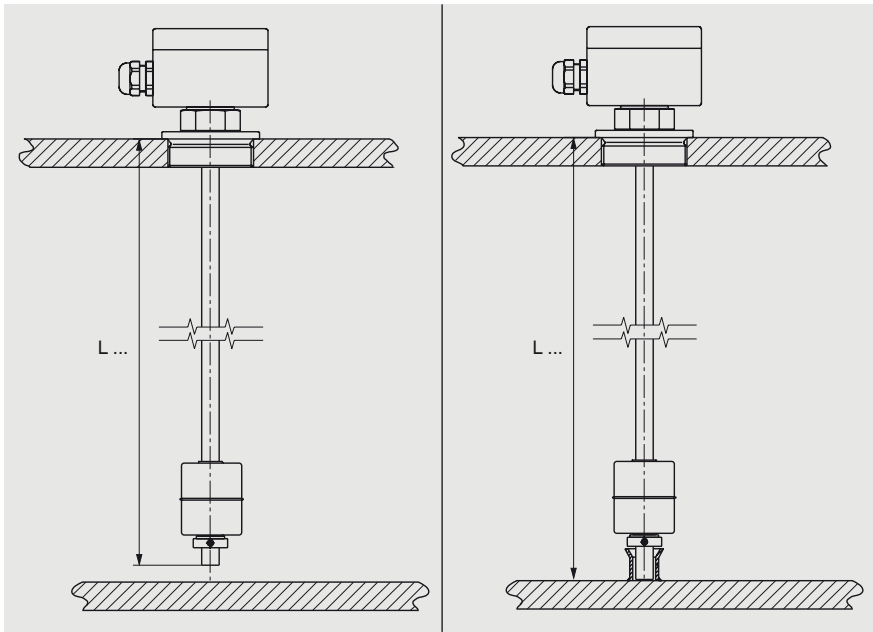

Guide tube	Max. guide tube length L		
	Version A	Version B	Version C
Ø 12 x 1	660 mm	3,500 mm	
Ø 14 x 1	940 mm	5,000 mm	
Ø 14 x 2	1,600 mm	6,000 mm	
Ø 18 x 2	3,000 mm	6,500 mm	
Ø 30 x 2	max. 15,000 mm		

Version C:

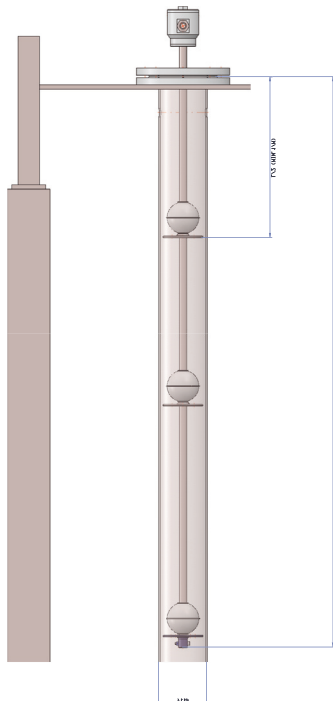
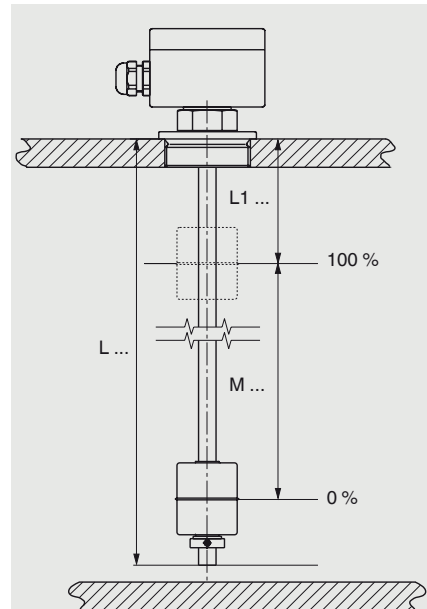

Illustration with the required dimensions for ordering



Legend

L1 = 100 % Mark (distance sealing face-float center)

M = measuring range (distance 0 ... 100 %)

L = guide tube length and/or. insertion length of the sensor

On ordering, the dimension L1 and the guide tube length (immersion length) L must be given.

Subsequent alteration of the measuring range is not possible.

Application examples

Standard applications

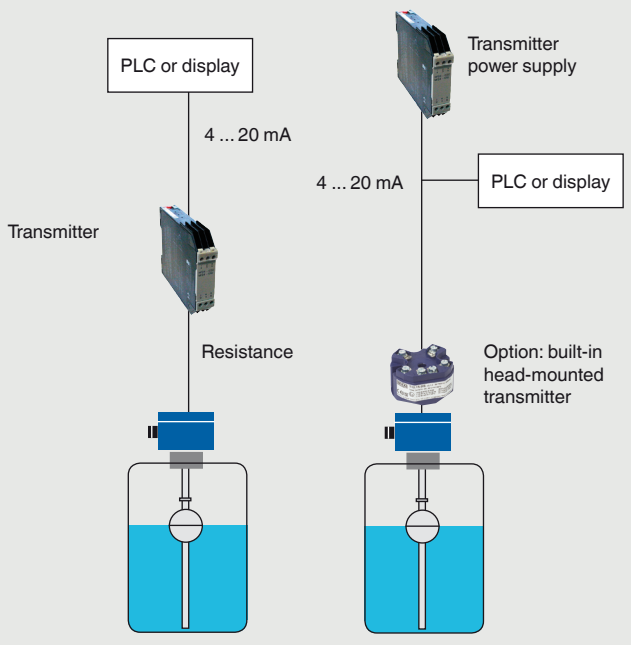

Connection to bus systems

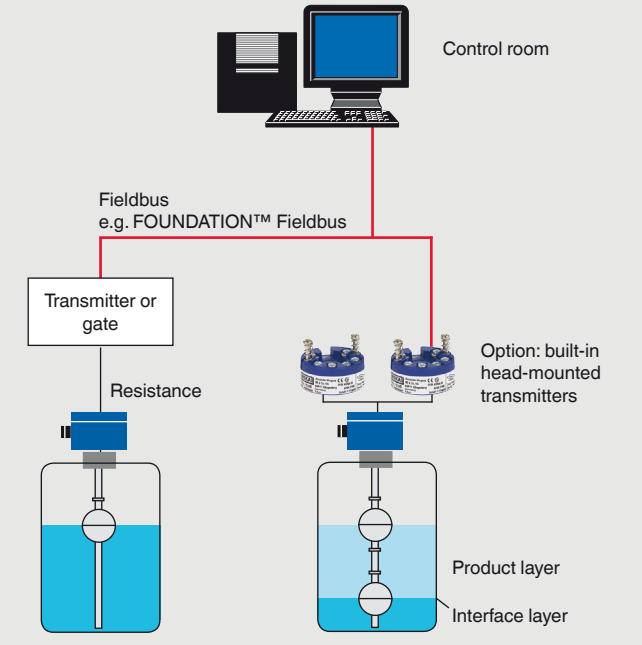

Applications for Ex-Zone 0

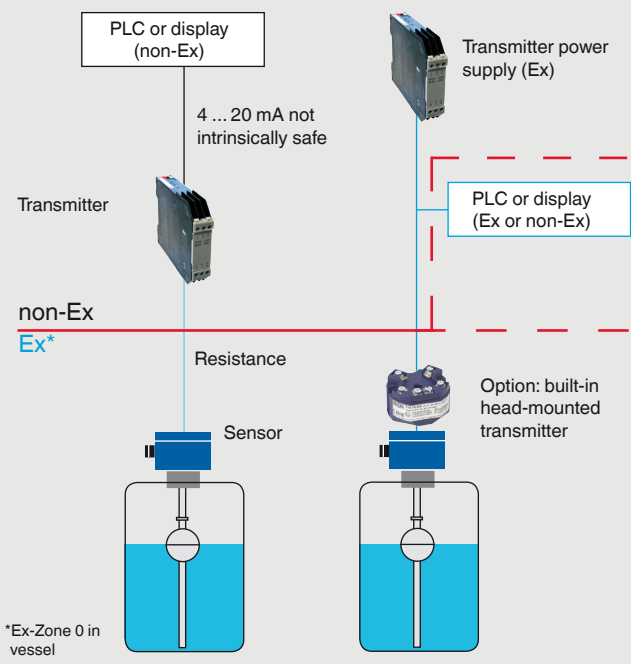

Applications for nuclear power plants

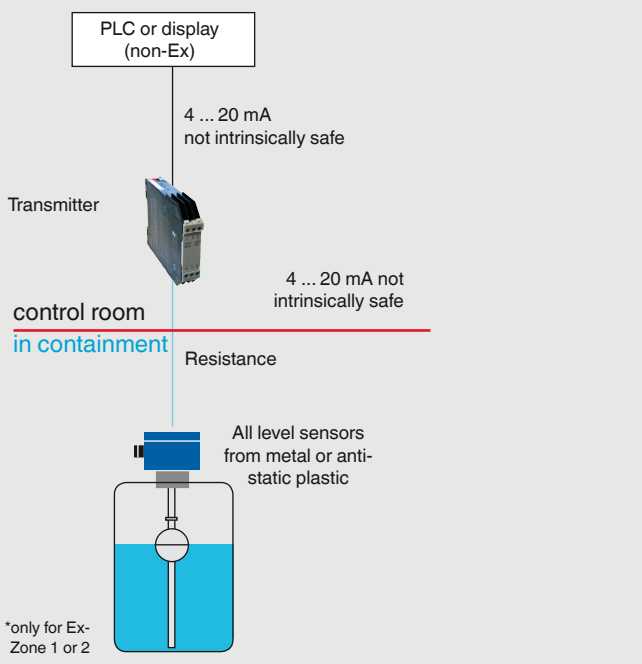

Measuring accuracy

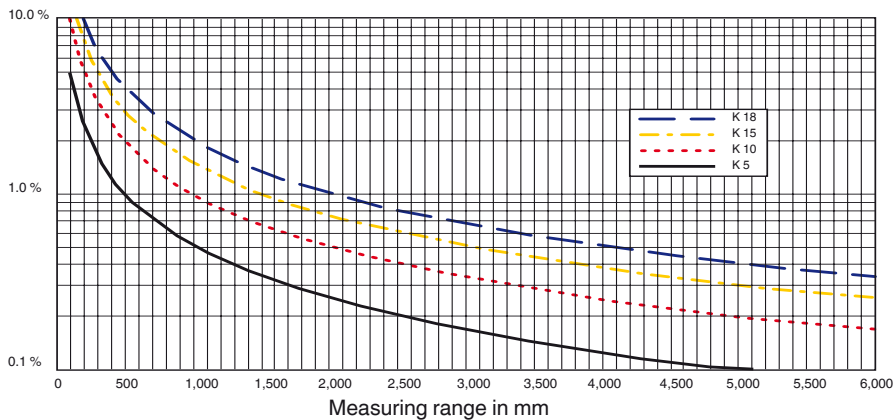

- Legend
- K 18 Contact separation 18 mm
 - K 15 Contact separation 15 mm
 - K 10 Contact separation 10 mm
 - K 5 Contact separation 5 mm

Head-mounted transmitter



Model TE

Model T32E

Model T53F

Model TLEH

Model	4 ... 20 mA	HART®	PROFIBUS® PA	Fieldbus™	Exi	IEEE	Display
TE	x				x	x	
TS	x						
T32E	x	x			x		
T32S	x	x					
T53F				x	x		
T53P			x		x		
TLH	x	x					x
TLEH	x	x			x		x

© 2014 KSR KUEBLER Niveau-Messtechnik AG, all rights reserved.
 The specifications given in this document represent the state of engineering at the time of publishing.
 We reserve the right to make modifications to the specifications and materials.



KSR KUEBLER Niveau-Messtechnik AG
 Heinrich-Kuebler-Platz 1
 69439 Zwingenberg/Germany
 Tel. +49 6263 87-0
 Fax +49 6263 8799
 info@ksr-kuebler.com
 www.ksr-kuebler.com