

Digital deadweight tester

Model CPD8500

WIKA data sheet CT 32.05

Applications

- Calibration laboratories
- Avionics / Aerospace equipment manufacturers
- Precision pressure sensor manufacturers
- Calibration service companies and service industry

Special features

- Measuring range up to 500 bar (up to 7,250 psi)
- On-board head memory
- Accuracy up to 35 ppm of reading
- Absolute and gauge pressure measurement
- No loading of masses required
- Intuitive touchscreen based user interface

Description

Design

The model CPD8500 digital deadweight tester is an instrument that combines the performance of a manual pressure balance with the efficiency and usability of a compact digital primary standard. The instrument offers a broad pressure range with various measuring heads from 1 ... 500 bar gauge (15 ... 7,250 psig) and 2 ... 20 bar abs (15 ... 290 psia). The CPD8500 digital deadweight tester is housed with an internal environmental monitoring module, a head temperature probe and a precision vacuum transducer for automatic detection of sensitive parameters. An optional internal or external barometric reference provides versatility with gauge or absolute pressure modes.

Application

Accuracies as high as 35 ppm of reading make the CPD8500 comparable to a reference primary standard and an ideal tool for calibrating transfer standards. In absolute mode, the CPD8500 offers continuous measurement, unlike a traditional piston gauge where vacuum is interrupted to load masses. This makes the instrument an easy and fast solution for premium calibrations. The internal automatic lubrication system drives higher and lower pressure ranges without the need for an additional pressure supply, limiting contamination and enhancing the piston cylinder system performance.



Digital deadweight tester, CPD8500

Ease of use

The CPD8500 utilizes proven piston gauge technology with a high accuracy load cell for precision calibration without the need to load any external mass sets. The displayed pressure value is internally compensated for changes in ambient conditions, local gravity and piston cylinder temperature. This eliminates the need for manual or external complex calculations.

The CPD8500 base has integral leveling feet for easy leveling. The feet are padded to reduce vibrational effects. The instrument also supports full backward compatibility to the absolute and gauge measuring heads of its predecessor, CPD8000.

Intuitive user interface

The CPD8500 digital deadweight tester is easy to use with the touchscreen display and an intuitive user interface. The software is capable of storing information of up to eight measuring heads for quick measuring head setup and operation. The CPD8500 software offers the ability to perform up to 11 point in-instrument adjustments on the various sensors installed inside. Additionally, the instrument can also be remotely controlled using either the Mensor standard or the CPD8000 command sets. There is an IEEE-488.2, RS-232, USB and Ethernet interface for communication with other instruments, so the CPD8500 can be integrated into existing systems.

Specifications

Model CPD8500

Measuring head including the piston cylinder system model CPS8500		
Pressure range	Piston cylinder system Kn ¹⁾	Lubrication media
Absolute pressure		
0 ... 2 bar (0 ... 29 psi)	0.2 bar / kg (2.9 psi / kg)	Dry, clean air or nitrogen
0 ... 5 bar (0 ... 72.5 psi)	0.5 bar / kg (7.25 psi / kg)	
0 ... 10 bar (0 ... 145 psi)	1 bar / kg (14.5 psi / kg)	
0 ... 20 bar (0 ... 290 psi)	2 bar / kg (29 psi / kg)	
Gauge pressure		
0 ... 1 bar (0 ... 14.5 psi)	0.1 bar / kg (1.45 psi / kg)	Dry, clean air or nitrogen
0 ... 2 bar (0 ... 29 psi)	0.2 bar / kg (2.9 psi / kg)	
0 ... 5 bar (0 ... 72.5 psi)	0.5 bar / kg (7.25 psi / kg)	
0 ... 10 bar (0 ... 145 psi)	1 bar / kg (14.5 psi / kg)	Dry, clean air or nitrogen over Drosera oil
0 ... 20 bar (0 ... 290 psi)	2 bar / kg (29 psi / kg)	Dry, clean air or nitrogen over Sebacate oil
0 ... 50 bar (0 ... 725 psi)	5 bar / kg (72.5 psi / kg)	
0 ... 100 bar (0 ... 1,450 psi)	10 bar / kg (145 psi / kg)	
0 ... 200 bar (0 ... 2,900 psi)	20 bar / kg (290 psi / kg)	
0 ... 500 bar (0 ... 7,250 psi)	50 bar / kg (725 psi / kg)	
Calibration interval	5 years	
Permissible pressure		
Permissible pressure media	Dry, clean air or nitrogen (ISO 8573-1:2010 class 5.5.4 or better)	
Maximum pressure	100% FS of the measuring head	
Connections		
Pressure port adapters (0 ... 2 bar abs. & 0 ... 5 bar abs.)	Standard: KF16 flange; Standard with coalescing filter: 1/8" NPT female	
Pressure port adapters (Gauge & 0 ... 10 bar abs., 0 ... 20 bar abs.)	Standard: 7/16-20 SAE female	
Wetted parts	2017 AL, 2024 AL, 303 SS, 304 SS, 316 SS, Tungsten Carbide, Sapphire, Buna N, FKM/ FPM, Silicone grease, Drosera oil, Sebacate oil, Urethane	
Filter elements (0 ... 2 bar abs. & 0 ... 5 bar abs.)	Pressure ports: 20 micron filters to prevent contamination Vacuum/vent ports: External 0.01 micron coalescing filter to prevent contamination when venting vacuum	

1) Kn is defined as the piston cylinder coefficient used to determine the pressure generated per kilogram of mass exerted on the CPD8500 chassis.

Total System Accuracy	
Standard accuracy ^{2) 3)}	50 ppm ⁵⁾
Premium accuracy ^{4) 6)}	35 ppm (compatible only with absolute and gauge CPS8500 up to 20 bar/290 psi)
Calibration interval	50 ppm: 2 years, 35ppm: 1 year

2) Accuracy is defined by the total measurement uncertainty, with the coverage factor (k = 2) and includes the intrinsic performance of the instrument, the measurement uncertainty of the reference instrument, long-term stability, influence of ambient conditions, drift and temperature effects over the compensated range with recommended zero point adjustment on power up.

3) Standard accuracy: Between 0 ... 25% of the full scale, the accuracy is 50 ppm of tenth of full scale value and between 25 ... 100% of the full scale, the accuracy is 50 ppm / 0.005% of reading

4) Premium accuracy: Between 0 ... 25% of the full scale, the accuracy is 35 ppm of tenth of full scale value and between 25 ... 100% of the full scale, the accuracy is 35 ppm / 0.0035% of reading

5) PPM = parts per million of the reading.

6) 35 ppm accuracy is warranted on a matched pair of CPS8500 and CPD8500 and the pair must be calibrated together

Base instrument	
Instrument	
Instrument version	Desktop case
Dimensions	See technical drawings
Weight	Absolute: approx. 23.5 kg (52 lbs) incl. all internal options without measuring head Gauge: approx. 18 kg (40 lbs) incl. all internal options without measuring head
Warm-up time	Up to 4 hours to rated accuracy

Base instrument

Display		
Screen	7.0" color LCD with resistive touchscreen	
Resolution	5 ... 8 digits depending on range and units	
Connections		
Pressure connections (Reference port/ Vacuum port)	Absolute: 2 ports with KF16 flanges	
Barometer port adapters	10-32 UNF port with 5/32 barb fitting	
Wetted parts	2017 AL, 2024 AL, 304 SS, 316 SS, Nickel, Buna N, FKM/ FPM, Silicone grease, Christo Lube MCG 1030, Urethane, PCTFE	
Permissible pressure		
Reference port/ Vacuum port	2 Pa ... 100 kPa abs. (15 mTorr ... 750 Torr abs.)	
Voltage supply		
Power supply	AC 100 ... 120 V, 50/60 Hz; AC 220 ... 240 V, 50/60 Hz	
Power consumption	max. 50 VA	
Permissible ambient conditions		
Storage temperature	-20 ... 70 °C (-4 ... 158 °F)	
Humidity	5 ... 95% r. h. (relative humidity non-condensing)	
Compensated temperature range	15 ... 40 °C (59 ... 104 °F)	
Mounting position	Horizontal	
Altitude	max. 3,048 meters	
Shock/ Vibration	max. 2 G	
Environmental monitoring module & Head temperature		
Sensor	Range	Accuracy ²⁾
Head temperature sensor	10 ... 40 °C (50 ... 104 °F)	0.5 °C
Ambient temperature sensor	-40 ... 125 °C (- 40 ... 257 °F)	1.0 °C
Relative humidity sensor	0 ... 100%	5% of relative humidity
Ambient pressure sensor	552 ... 1,170 mbar abs (8 ... 17 psi abs)	2% reading
Calibration interval	2 years	
Residual vacuum		
Sensor	Range	Accuracy ²⁾
High accuracy vacuum sensor	0.1 ... 1000 mtorr	0.8% of reading
Calibration interval	2 years	
Communication		
Interface	Standard: Ethernet, IEEE-488, USB, RS-232.	
Command sets	Mensor and CPD8000	
Response time	approx. 100 ms	

Approvals and certificates

EC declaration of conformity	
EMC directive ⁸⁾	EN 61326-1 emission (group 1, class A) and interference immunity (industrial application)
Low voltage directive	EN 61010-1
RoHS directive	2011/65/EU, article 4

Certificate	
Calibration ⁹⁾	Standard: A2LA calibration certificate (standard on factory) Optional: DKD/DAkkS calibration certificate

⁸⁾ **Warning!** This is class A equipment for emissions and is intended for use in industrial environments. In other environments, e.g. residential or commercial installations, it can interfere with other equipment under certain conditions. In such circumstances the operator is expected to take the appropriate measures.

⁹⁾ Calibration in a horizontal position/operating position.

Approvals and certificates, see website

Reliable efficiency with the performance of a primary standard

The working principle

The CPD8500 works on a unique principle which follows the fundamental operating principle of a pressure balance or piston gauge. The pressure is applied on the measuring head to the effective area of the piston and converted into a proportional force. The force is transferred to the measuring load cell housed inside the base. The measuring load cell continuously measures and calculates the pressure-generated force. The base converts the measured force to the equivalent pressure and corrects for the environmental influences.

Auto detection of ambient conditions

The CPD8500 digital deadweight tester is equipped with an internal environmental monitoring module (EMM) to constantly monitor any changes in ambient pressure, temperature and relative humidity. Changes in ambient parameters have significant effect on the validity of pressure readings. The instrument informs the user of the changes to these conditions and activates quick calibration to ensure premium performance. The EMM is easily interchanged and removed for calibration and repair.

Auto detection of piston cylinder health

The CPS8500 measuring head houses a piston cylinder assembly to convert pressure into force. A motor keeps the piston inside the cylinder rotating to maintain equilibrium. The CPD8500 automatically detects contaminants inside the piston cylinder assembly and prevents damage to the instrument.

Multiple heads for one base

The CPD8500 base supports up to 8 measuring head configurations at one time, allowing a wide operating range with one base. The measuring heads can be removed, exchanged and installed for best performance with a few easy steps. Each head configuration can be copied to the base with a USB to ensure swift & correct entry of all parameters.

Compatibility

The CPD8500 digital deadweight tester is capable of accessing all the features of the CPS8500 while also being completely backward compatible with the measuring heads for its predecessor, CPD8000. The absolute measuring heads Legacy models 610, 410, 110 & 111 can be installed on the CPD8500 base to continue utilizing the existing measuring heads.

CPS8500 Measuring Head

The CPS8500 is equipped with onboard flash memory that stores all head data information needed to provide accurate calibrations and readings through the calibration interval. The CPD8500 and CPS8500 connect with a mounted switch that enables the head information to automatically transmit all data to the CPD8500.

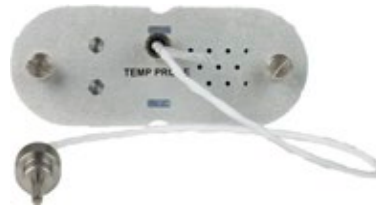
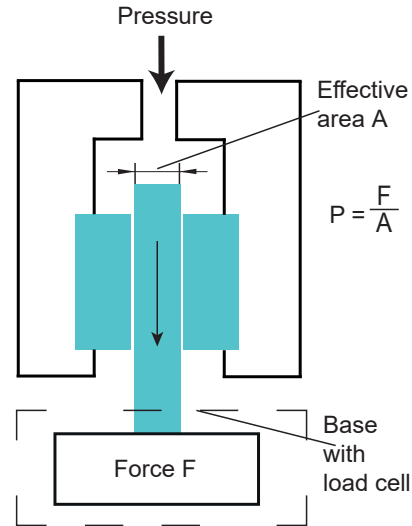

Removable EMM with head temperature probe



Legacy Absolute



Legacy Gauge



CPS8500A



CPS8500G

Absolute & Gauge measuring heads

Touchscreen and intuitive operator interface

Shortly after power-up, the standard main screen (see following picture) is displayed. This is the Home application displaying all the necessary information to operate and read pressure from the CPD8500. The color of the current pressure value (12) indicates the validity and stability of the reading. The customizable auxiliary menu (9) displays measurements from various sensors within the instrument. The various applications on the right one third of the screen provide access to setup menus like the measuring head details, stable limits for the EMM, instrument settings and properties.

Standard desktop/main screen

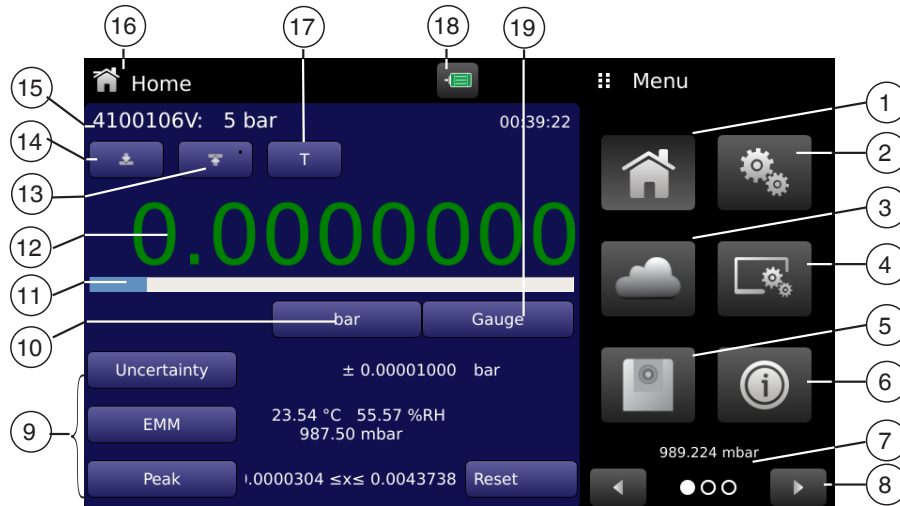

- | | |
|---|----------------------------|
| ① Home application | ⑪ Bar graph |
| ② General settings | ⑫ Current measuring value |
| ③ EMM settings | ⑬ Span adjustment function |
| ④ Display settings | ⑭ Zero adjustment function |
| ⑤ Head settings | ⑮ Current measuring head |
| ⑥ Information application | ⑯ Current application |
| ⑦ Barometric pressure reading (optional) | ⑰ Tare adjustment function |
| ⑧ Menu scroll features forward / back | ⑱ Motor status icon |
| ⑨ Auxiliary displays either peak, rate or alternate units | ⑲ Current pressure mode |
| ⑩ Current pressure unit | |

Dimensions in mm [in]

Absolute version

Front view

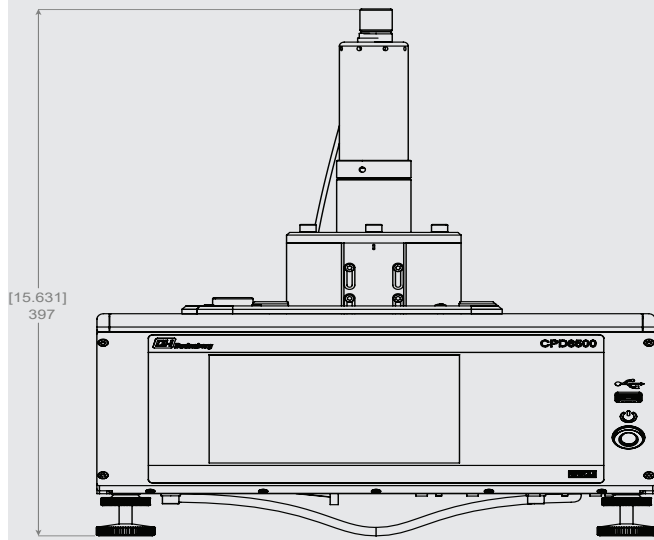

Side view (left)

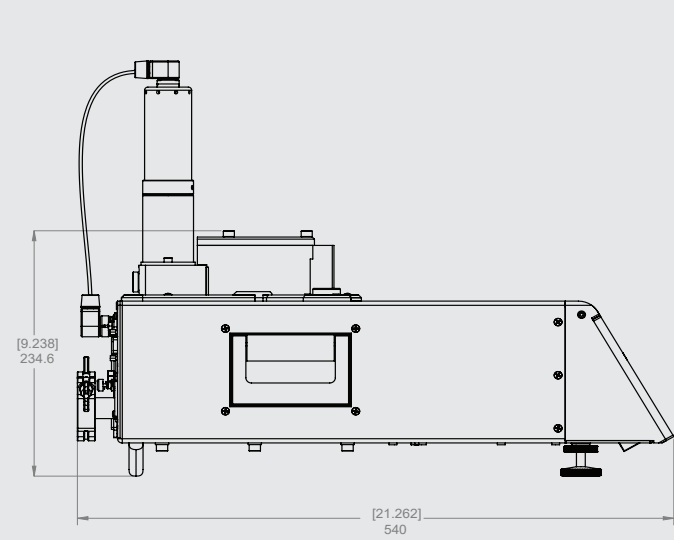

Gauge version

Front view

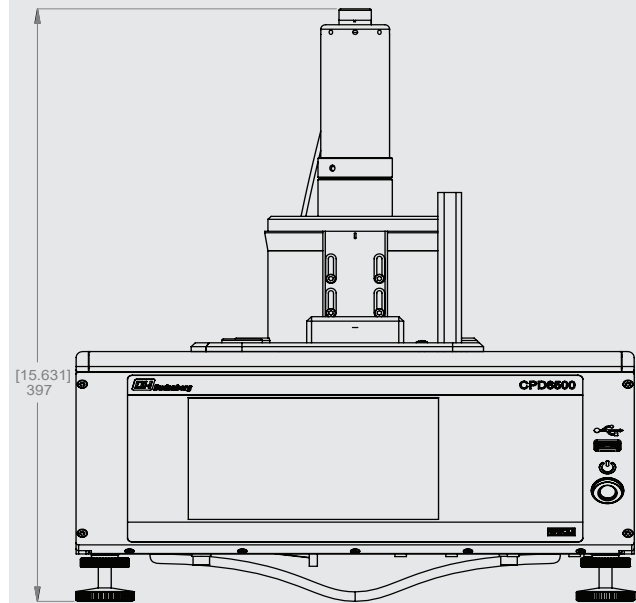

Side view (left)

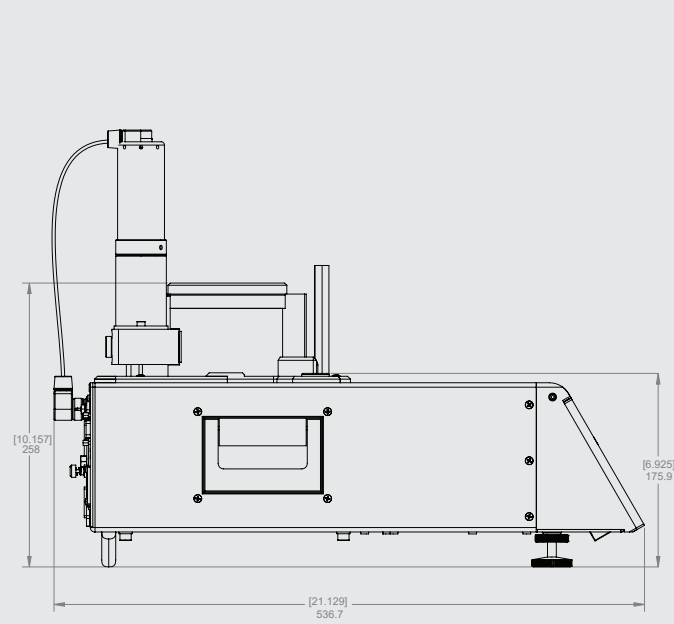

Electrical and pressure connections - rear view

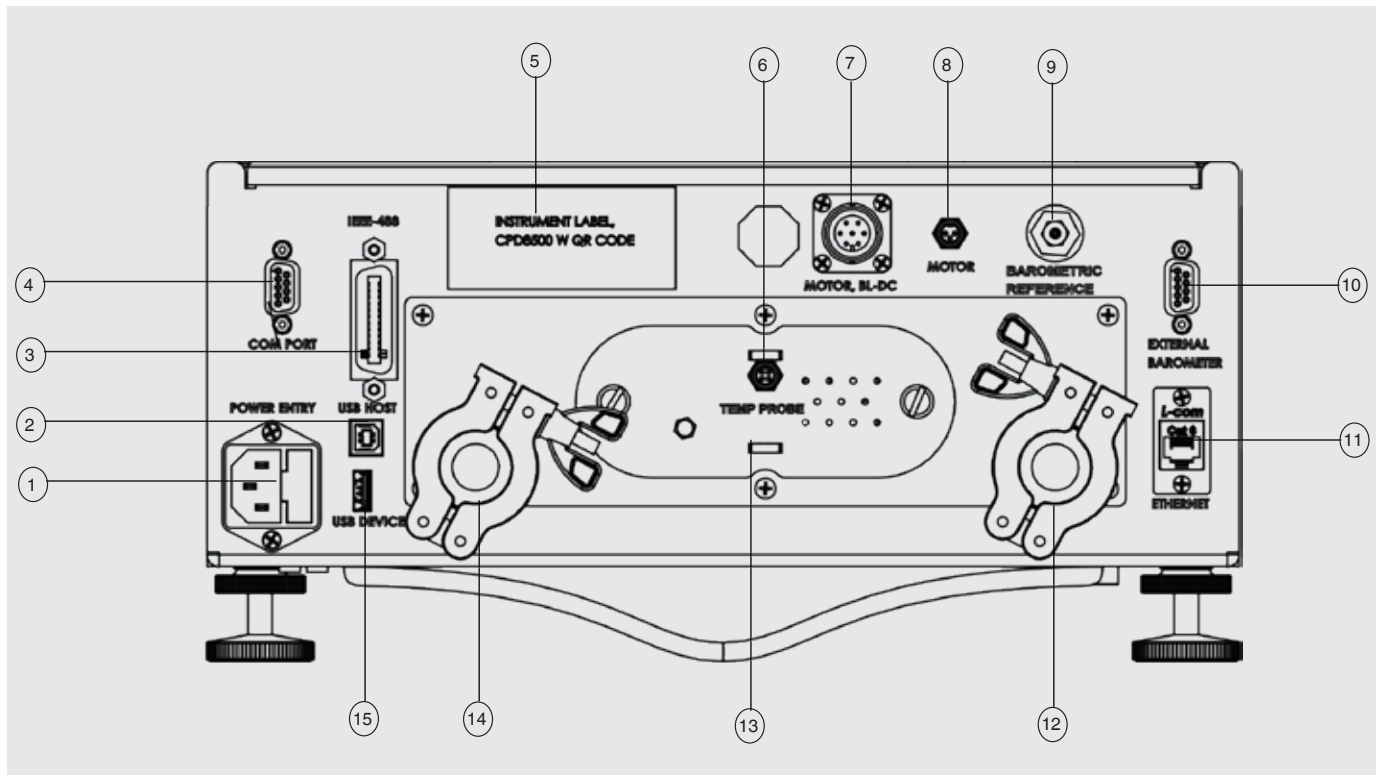

- | | |
|------------------------------------|---|
| ① Power adapter | ⑧ Brushed motor interface |
| ② USB host | ⑨ Internal barometric reference port |
| ③ IEEE-488 interface | ⑩ External barometric reference interface |
| ④ RS-232 interface | ⑪ Ethernet port |
| ⑤ Instrument label | ⑫ Vacuum reference pressure port to measuring head (abs version only) |
| ⑥ Head temperature probe interface | ⑬ Environmental monitoring module (EMM) |
| ⑦ Brushless DC motor interface | ⑭ Vacuum reference pressure port to vacuum pump (abs version only) |

Scope of delivery

- Digital deadweight tester CPD8500
- Accessory kit for gauge/ absolute
- 1.5 m (5 ft) power cord
- Operating instructions
- A2LA calibration certificate for standard accuracy
- Transport case for one CPD8500 & CPS8500
- Adapters and fittings for pressure connections

Accessories

- Gauge to absolute adapter
- Transport case for up two CPS8500
- Lubrication Fluid (gauge heads only)
- Calibration Adapters

Options

- Measuring head CPS8500
- A2LA calibration certificate for premium accuracy
- Barometric reference
- External mass set for linearization

Ordering information

CPD8500

Model / Base type / Barometric reference / Type of certificate for barometric reference / Base calibration type / External mass set / Type of accessory kit / Type of power cable / Additional approvals / Additional ordering information

CPS8500

Model / Pressure type / Measuring head range / Type of calibration for gauge / Type of calibration for absolute / Pressure adapter / Transport case / Additional approvals / Additional ordering information

© 09/2018 WIKA Alexander Wiegand SE & Co. KG, all rights reserved.
The specifications given in this document represent the state of engineering at the time of publishing.
We reserve the right to make modifications to the specifications and materials.



Mensor

201 Barnes Drive
San Marcos, TX 78666
Tel. (512) 396-4200
Fax (512) 396-1820
sales@mensor.com
www.mensor.com